

	NAME	FONCTION	VISA
AUTHOR	Alain Battistini	Senior Engineer	CONFORM TO ORIGINAL
REVIEW	Jean-François Hoh	Senior Engineer	CONFORM TO ORIGINAL
APPROVAL	Pascal Gilbert-Jeantet		CONFORM TO ORIGINAL

Revision History			
Revision	Date	Who	Change
A	28-Dec-00	ABA	Creation for Dx Server 4.0.2
B	26-Jun-02	ABA	Updated for Dx Server 5.0.0
C	24-Sep-02	ABA	Added storage commitment
D	13-Feb-03	ABA	Added MPPS and Presentation State
E	19-Sep-03	ABA	Added Key Object Document Selection
F	04-Apr-05	ABA	Added Security

Table of Contents

1	Introduction	4
1.1	Scope and audience	4
1.2	References	4
1.3	Acronyms and abbreviations	4
2	Implementation model.....	5
2.1	Application data flow diagram	5
2.1.1	Respond to verification requests	5
2.1.2	Accept objects received from a DICOM SCU	6
2.1.3	Accept Storage Commitment Requests	6
2.1.4	Respond to C-FIND queries	6
2.1.5	Respond to C-MOVE queries	8
2.1.6	Respond to DICOM Basic Modality Worklist queries	8
2.1.7	Respond to Prefetching or Routing requests	9
2.1.8	Accept and forward Modality Performed Procedure Step	9
2.2	Functional definition of Application Entities	10
2.3	Sequencing of Real World Activities	10
3	Application Entity specifications	10

3.1	DxServer AE Specifications	10
3.1.1	Association establishment policies for DxServer AE	12
3.1.1.1	General	12
3.1.1.2	Number of associations	13
3.1.1.3	Asynchronous nature	13
3.1.1.4	Implementation identifying information	13
3.1.2	Association initiation for DxServer AE	13
3.1.2.1	Verify Communication with a Remote System	13
3.1.2.1.1	Associated real-world activity	13
3.1.2.1.2	Proposed Presentation Contexts	13
3.1.2.1.3	SOP specific conformance	14
3.1.2.2	Send Objects to a Remote System	14
3.1.2.2.1	Associated real-world activity	14
3.1.2.2.2	Proposed Presentation Contexts	14
3.1.2.2.3	SOP specific conformance	15
3.1.2.3	Verify the Committed Storage of Instances on a Remote System	16
3.1.2.3.1	Proposed Presentation Contexts	16
3.1.2.3.2	SOP specific conformance	16
3.1.2.4	Forward MPPS requests to a Remote System	16
3.1.2.4.1	Proposed Presentation Contexts	16
3.1.2.4.2	SOP specific conformance	17
3.1.3	Association acceptance policy for DxServer AE	17
3.1.3.1	Verify Communication with a Remote System	17
3.1.3.1.1	Associated real-world activity	17
3.1.3.1.2	Accepted Presentation Contexts	17
3.1.3.1.3	SOP Specific Conformance	18
3.1.3.1.4	Presentation Context Acceptance Criterion	18
3.1.3.2	Receive Objects from a Remote System	18
3.1.3.2.1	Associated real-world activity	18
3.1.3.2.2	Accepted Presentation Contexts	19
3.1.3.2.3	SOP Specific Conformance	20
3.1.3.2.4	Presentation context acceptance criterion	20
3.1.3.2.5	Transfer syntax selection policies	20
3.1.3.3	Query the Dx Server Database and Retrieve Objects	20
3.1.3.3.1	Associated real-world activity	20
3.1.3.3.2	Accepted Presentation Contexts	21
3.1.3.3.3	SOP Specific Conformance	21
3.1.3.3.4	Presentation Context Acceptance Criterion	25
3.1.3.4	Commit Storage of Images in DxServer	25
3.1.3.4.1	Associated Real World Activity	25
3.1.3.4.2	Accepted Presentation Contexts	25
3.1.3.4.3	SOP specific conformance	25
3.1.3.4.4	Presentation context acceptance criterion	25
3.1.3.5	Inform DxServer about Procedure Step	26
3.1.3.5.1	Associated Real World Activity	26
3.1.3.5.2	Accepted Presentation Contexts	26
3.1.3.5.3	SOP specific conformance	26
3.1.3.5.4	Presentation context acceptance criterion	27
3.2	DxBroker AE Specifications	28
3.2.1	Association establishment policies for DxBroker AE	28

3.2.1.1	General	28
3.2.1.2	Number of associations	28
3.2.1.3	Asynchronous nature	29
3.2.1.4	Implementation identifying information	29
3.2.2	Association initiation for DxBroker AE	29
3.2.3	Association acceptance policy for DxBroker AE	29
3.2.3.1	Verify Communication with a Remote System	29
3.2.3.1.1	Associated real-world activity	29
3.2.3.1.2	Accepted Presentation Contexts	29
3.2.3.1.3	SOP Specific Conformance to Verification SOP Class	29
3.2.3.1.4	Presentation Context Acceptance Criterion	29
3.2.3.2	Query the Dx Broker Work list	30
3.2.3.2.1	Associated real-world activity	30
3.2.3.2.2	SOP Specific Conformance	30
4	Communication Profiles	32
4.1	Supported Communications Stacks	32
4.2	TCP/IP Stack	32
4.3	Physical Media Support	32
5	Extensions / Specializations / Privatizations	32
6	Configuration.....	33
7	Support of extended character sets.....	33

1 INTRODUCTION

1.1 SCOPE AND AUDIENCE

This document is a DICOM Conformance Statement for DxServer. DxServer is a DICOM server that can store DICOM images from modalities and DICOM clients can access it to retrieve these images.

This document has been written using the guidelines provided in the DICOM standard [2 – part 2].

Note: The French ISO member body AFNOR has provided Medasys Digital Systems with an UID root. This UID root is only in numerical form as following: 1.2.250.1.38

1.2 REFERENCES

- [1] Dx Server Installation and Configuration Guide
- [2] ACR/NEMA Standards Publications, No PS3, DICOM Standards:
 - Part 1 – Introduction
 - Part 2 – Conformance
 - Part 3 – Information Object Definitions
 - Part 4 – Service Class Specifications
 - Part 5 – Data Structures and Encoding
 - Part 6 – Data Dictionary
 - Part 7 – Message Exchange
 - Part 8 – Network Communication Support
 - Part 9 – Point to Point Communication Support for Message Exchange
 - Part 10 – Media Storage and File Format for Media Interchange
 - Part 11 – Media Storage Application Profiles
 - Part 12 – Storage Functions and Media Formats for Data Interchange
 - Part 13 – Print Management Point-to-Point Communication Support

1.3 ACRONYMS AND ABBREVIATIONS

The following symbols and abbreviations are used in this conformance statement:

ACR:	American College of Radiology
AE:	DICOM Application Entity
DICOM:	Digital Imaging and Communication in Medicine
DIMSE:	DICOM Message Service Element
GSPPS:	Grayscale Softcopy Presentation State
HIS:	Hospital Information System
IOD:	DICOM Information Object Definition

ISO:	International Standard Organization
KO:	Key Object Selection Document
MPPS:	Modality Performed Procedure Step
MWL:	Modality Work List
NEMA:	National Electrical Manufacturers Association
RIS:	Radiology Information System
PDU:	DICOM Protocol Data Unit
SCP:	DICOM Service Class Provider
SCU:	DICOM Service Class User
SOP:	DICOM Service-Object Pair
TCP/IP:	Transmission Control Protocol / Internet Protocol
UID	Unique Identifier
VR :	Value Representation

2 IMPLEMENTATION MODEL

The primary functions provided by DxServer are:

1. Respond to verification requests from a DICOM Verification SCU
2. Accept objects from a DICOM storage service class user. Place the objects in an images folder. Maintain an object database containing attributes of the objects.
3. Respond to requests from DICOM Query/Retrieve service class users for retrieval of objects.
4. Act as a DICOM Storage Service class user in response to prefetching or routing requests for sending objects to a remote DICOM AE.

The primary function provided by DxBroker

1. Respond to DICOM Basic Modality Worklist queries when connected to DxBroker.

2.1 APPLICATION DATA FLOW DIAGRAM

2.1.1 RESPOND TO VERIFICATION REQUESTS

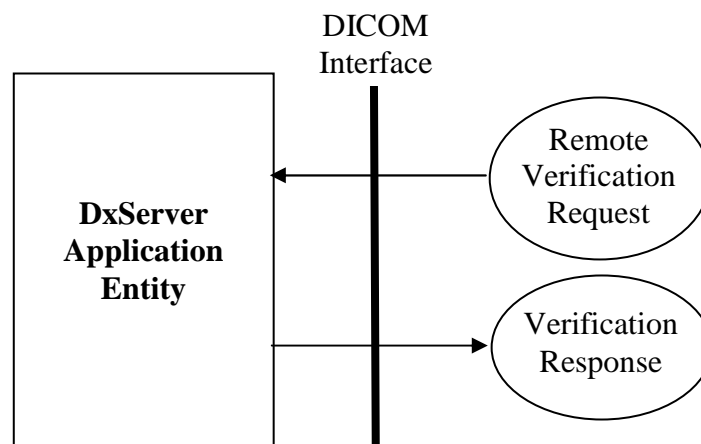

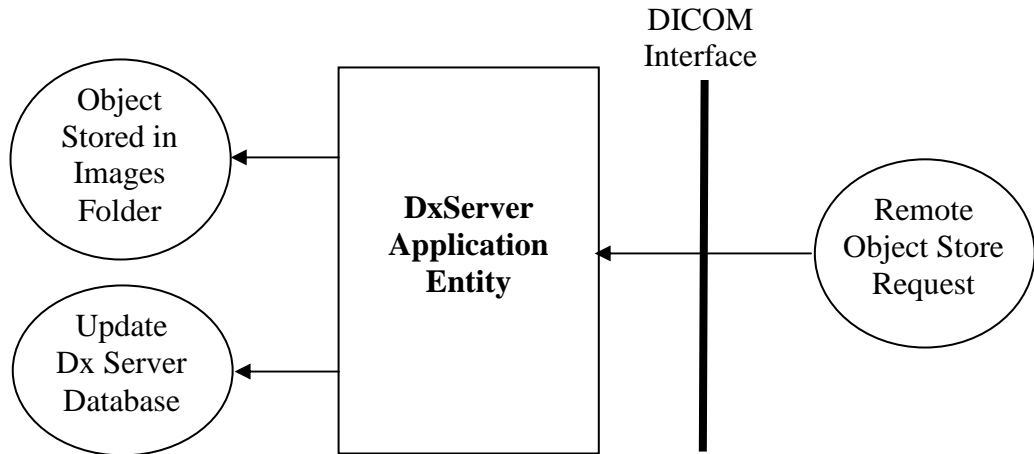
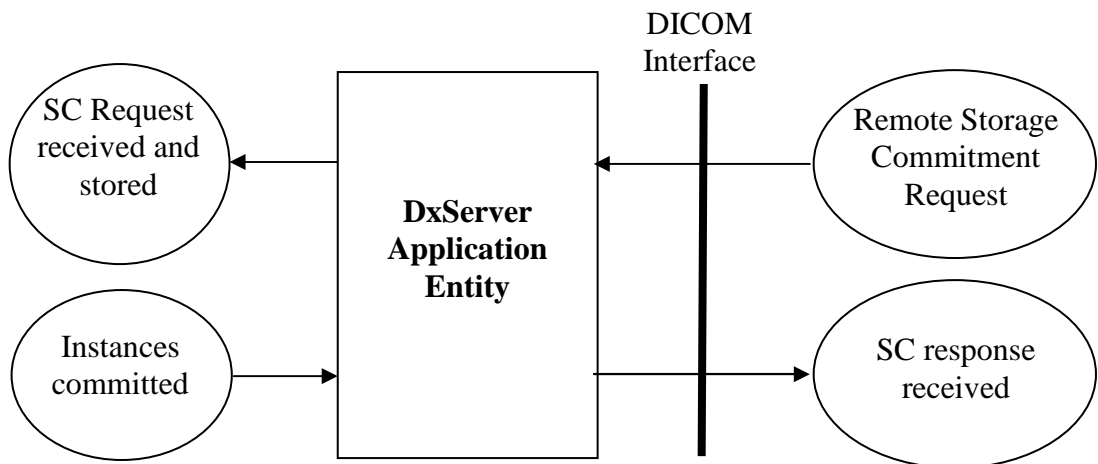
2.1.2 ACCEPT OBJECTS RECEIVED FROM A DICOM SCU**2.1.3 ACCEPT STORAGE COMMITMENT REQUESTS**

The response can be sent in the same or in a different association.

2.1.4 RESPOND TO C-FIND QUERIES

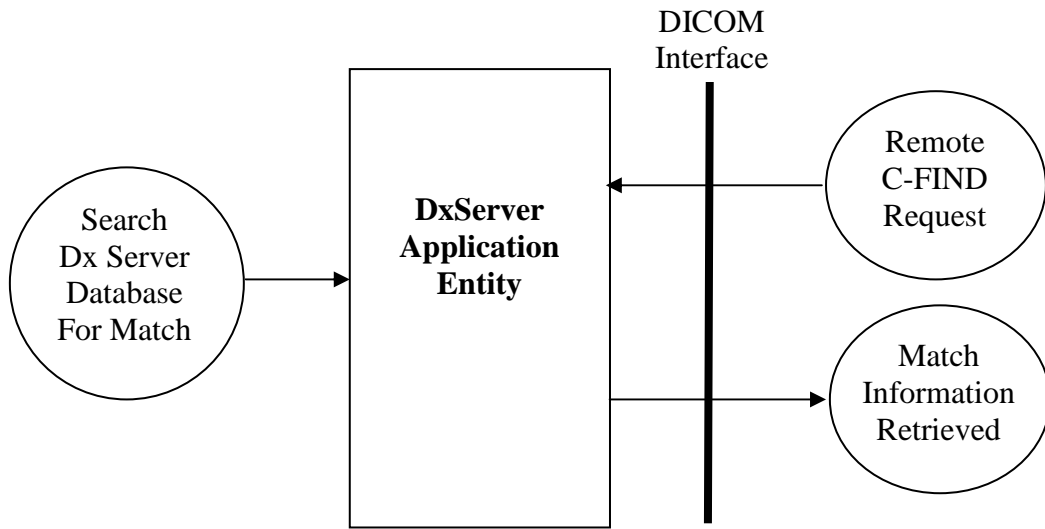

2.1.5 RESPOND TO C-MOVE QUERIES

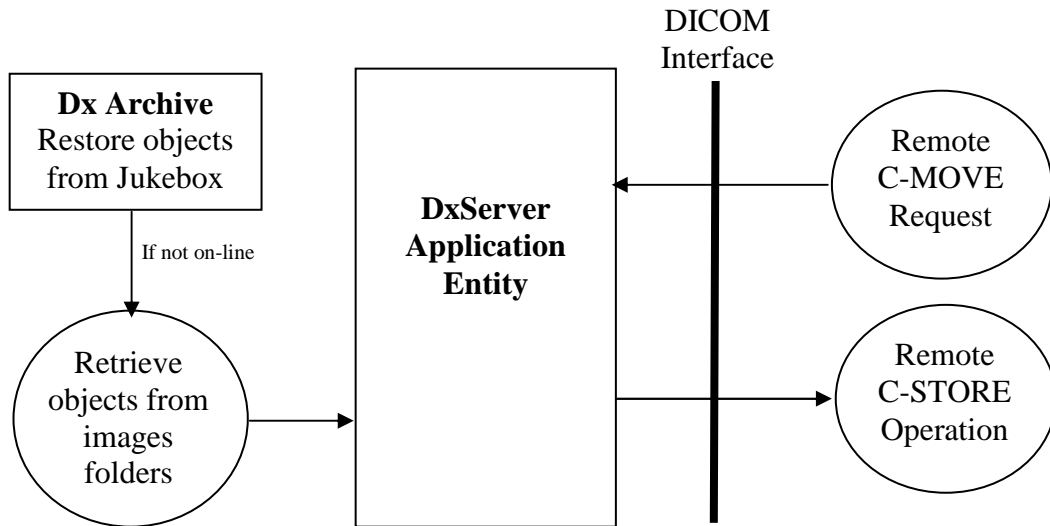

2.1.6 RESPOND TO DICOM BASIC MODALITY WORKLIST QUERIES

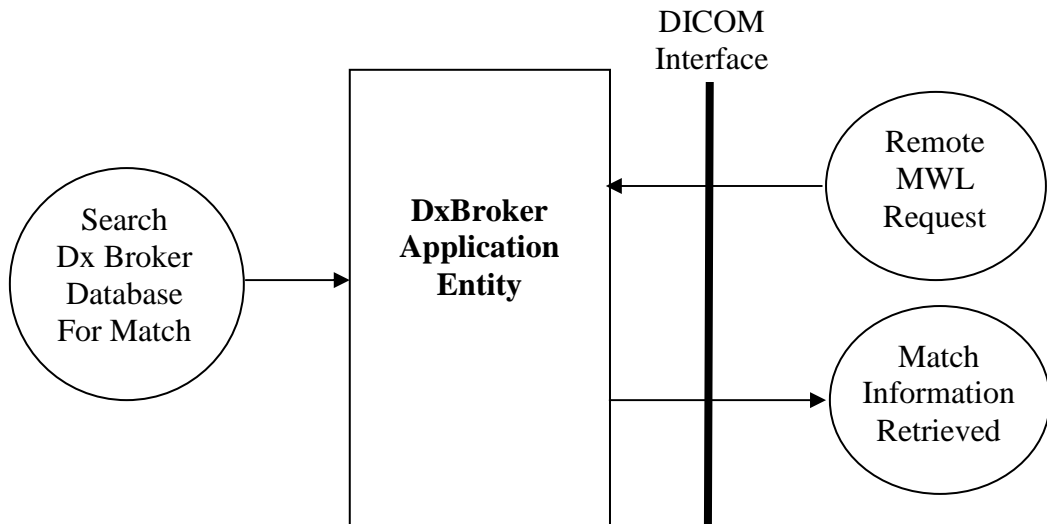

2.1.7 RESPOND TO PREFETCHING OR ROUTING REQUESTS

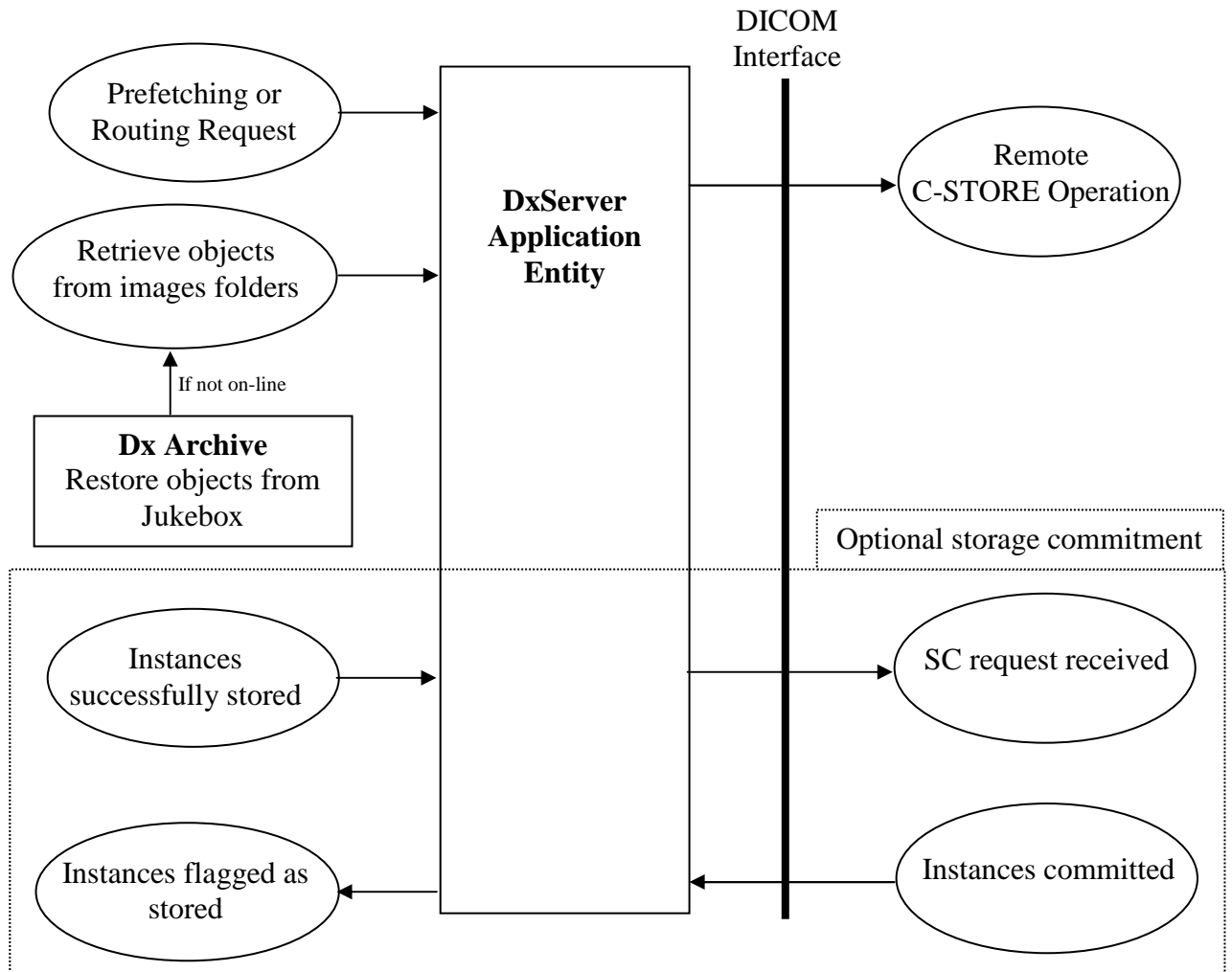

2.1.8 ACCEPT AND FORWARD MODALITY PERFORMED PROCEDURE STEP

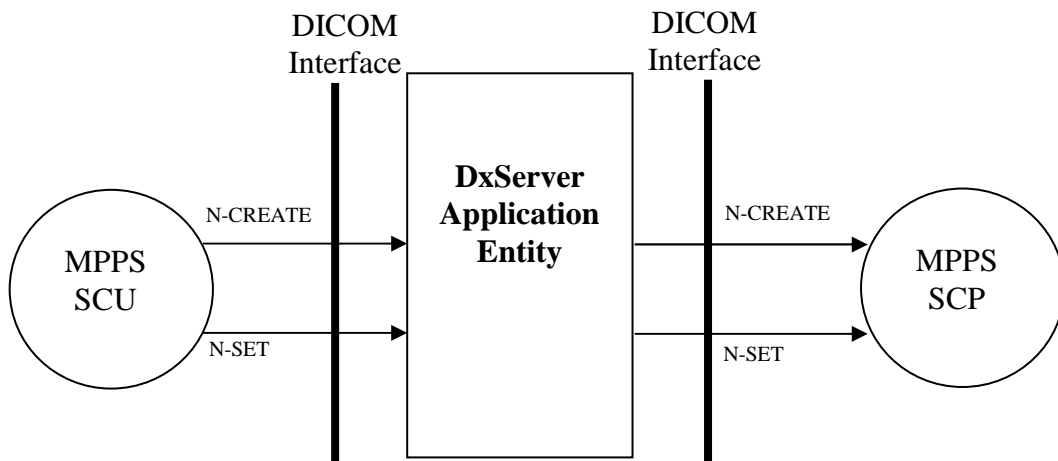

2.2 FUNCTIONAL DEFINITION OF APPLICATION ENTITIES

DxServer application entity acts as a Service Class Provider (SCP) for the following service classes:

- Verification Service Class
- Storage Service Class
- Query/Retrieve Service Class
- Storage Commitment Service Class
- MPPS Service Class

DxServer application entity acts as a Service Class User (SCU) for the following service classes:

- Verification Service Class
- Storage Service Class
- Storage Commitment Service Class
- MPPS Service Class

DxBroker application entity acts as a Service Class Provider (SCP) for the following service classes:

- Verification Service Class
- Basic Modality Worklist Service Class

2.3 SEQUENCING OF REAL WORLD ACTIVITIES

Not applicable.

3 APPLICATION ENTITY SPECIFICATIONS

3.1 DXSERVER AE SPECIFICATIONS

Verification SOP Class

The **DxServer** AE provides standard conformance to the following DICOM V3.0 Service Object Pair (SOP) Class as a Verification Service Class User (SCU) and Provider (SCP). As an SCU it sends an Echo request when routing image to a remote AE. As an SCP it sends an Echo response when it receives an Echo request from a remote AE.

Table 1: Valid SCU/SCP Verification SOP Class for DxServer AE

SOP Class UID	SOP Class Name
1.2.840.10008.1.1	Verification SOP Class

Storage SOP Classes

The **DxServer** AE provides standard conformance to the following DICOM V3.0 SOP Classes as an SCP when servicing requests to store objects. It also supports these SOP Classes as an SCU when servicing move requests and routing requests.

Table 2: Valid SCU/SCP Storage SOP Classes for DxServer AE

SOP Class UID	SOP Class Name
1.2.840.10008.5.1.4.1.1.1	Computed Radiography Image Storage
1.2.840.10008.5.1.4.1.1.1.1	Digital X-Ray Image Storage – For Presentation
1.2.840.10008.5.1.4.1.1.1.1.1	Digital X-Ray Image Storage – For Processing
1.2.840.10008.5.1.4.1.1.1.2	Digital Mammography X-Ray Image Storage – For Presentation
1.2.840.10008.5.1.4.1.1.2	CT Image Storage
1.2.840.10008.5.1.4.1.1.3	Ultrasound Multi-frame Image Storage (retired)
1.2.840.10008.5.1.4.1.1.3.1	Ultrasound Multi-frame Image Storage
1.2.840.10008.5.1.4.1.1.4	MR Image Storage
1.2.840.10008.5.1.4.1.1.5	Nuclear Medicine Image Storage (retired)
1.2.840.10008.5.1.4.1.1.6	Ultrasound Image Storage (retired)
1.2.840.10008.5.1.4.1.1.6.1	Ultrasound Image Storage
1.2.840.10008.5.1.4.1.1.7	Secondary Capture Image Storage
1.2.840.10008.5.1.4.1.1.11.1	Grayscale Softcopy Presentation State Storage
1.2.840.10008.5.1.4.1.1.12.1	X-Ray Angiographic Image Storage
1.2.840.10008.5.1.4.1.1.12.2	X-Ray Radiflouroscopic Image Storage
1.2.840.10008.5.1.4.1.1.12.3	X-Ray Angiographic Bi-plane Image Storage
1.2.840.10008.5.1.4.1.1.20	Nuclear Medicine Image Storage
1.2.840.10008.5.1.4.1.1.88.59	Key Object Selection Document
1.2.840.10008.5.1.4.1.1.128	Positron Emission Tomography (PET) Image Storage
1.2.840.10008.5.1.4.1.1.481.1	Radiotherapy (RT) Image Storage
1.2.840.10008.5.1.4.1.1.481.2	Radiotherapy (RT) Dose Storage
1.2.840.10008.5.1.4.1.1.481.3	Radiotherapy (RT) Structure Set Storage
1.2.840.10008.5.1.4.1.1.481.4	Radiotherapy (RT) Beams Treatment Record Storage
1.2.840.10008.5.1.4.1.1.481.5	Radiotherapy (RT) Plan Storage
1.2.840.10008.5.1.4.1.1.481.6	Radiotherapy (RT) Brachy Treatment Record Storage
1.2.840.10008.5.1.4.1.1.481.7	Radiotherapy (RT) Summary Treatment Record Storage

Query/Retrieve SOP Classes

The **DxServer** AE provides standard conformance to the following DICOM V3.0 SOP Classes as a Query/Retrieve SCP, when servicing queries about objects that have been stored. Extended negotiation for relational queries is not supported.

Table 3: Valid SCP Query/Retrieve SOP Class for DxServer AE

SOP Class UID	SOP Class Name
1.2.840.10008.5.1.4.1.2.1.1	Patient Root Query/Retrieve Information Model – Find
1.2.840.10008.5.1.4.1.2.1.2	Patient Root Query/Retrieve Information Model – Move
1.2.840.10008.5.1.4.1.2.1.3	Patient Root Query/Retrieve Information Model – Get
1.2.840.10008.5.1.4.1.2.2.1	Study Root Query/Retrieve Information Model – Find
1.2.840.10008.5.1.4.1.2.2.2	Study Root Query/Retrieve Information Model – Move
1.2.840.10008.5.1.4.1.2.2.3	Study Root Query/Retrieve Information Model – Get

Storage Commitment SOP Class

The **DxServer** AE provides standard conformance to the following DICOM V3.0 Service Object Pair (SOP) Class as a Storage Commitment Service Class User (SCU) and Provider (SCP). As an SCP, it services storage commitment requests about objects that have been or will be stored. As an SCU, it sends a storage commitment request after routing images to a remote AE.

Table 4: Valid SCU/SCP Storage Commitment SOP Class for DxServer AE

SOP Class UID	SOP Class Name
1.2.840.10008.1.20.1	Storage Commitment Push Model SOP Class

Modality Performed Procedure Step SOP Class

The **DxServer** AE provides standard conformance to the following DICOM V3.0 Service Object Pair (SOP) Class as a Modality Performed Procedure Step Service Class User (SCU) and Provider (SCP). As an SCP, it services MPPS N-CREATE and N-SET requests. As an SCU, it forwards MPPS N-CREATE and N-SET to a remote AE.

Table 5: Valid SCU/SCP Modality Performed Procedure Step SOP Class for DxServer AE

SOP Class UID	SOP Class Name
1.2.840.10008.3.1.2.3.3	Modality Performed Procedure Step SOP Class

3.1.1 ASSOCIATION ESTABLISHMENT POLICIES FOR DXSERVER AE

3.1.1.1 GENERAL

All associations with the DxServer AE shall be established using the DICOM 3.0 Application Context. A single DICOM Application Context Name is defined for this version of the DICOM standard. This name is “**1.2.840.10008.3.1.1.1**”.

The DxServer AE accepts association for the following purposes:

- Supports the **C-ECHO** service to allow end-to-end verifications.
- Supports the **C-STORE** service to store objects into the database.
- Supports the **C-FIND** service to search the database.
- Supports the **C-MOVE** service to retrieve objects from the database.
- Supports the **C-GET** service to retrieve objects from the database.
- Supports the **Storage Commitment** service to commit storage of objects into the database.
- Supports the **MPPS** service to create and set modality performed procedure step objects into the database.

The DxServer AE initiates associations for the following purposes:

- Invokes the **C-STORE** service to send objects, as sub-operations of a remote C-MOVE service request, or when DxBroker sends a routing or prefetching request.
- Invokes the **C-ECHO** service before invoking a C-STORE (can be disabled by configuration).
- Invokes the **Storage Commitment** service after invoking a C-STORE to be sure that the instances are really managed by the remote system (can be disabled by configuration).

- Invokes the **MPPS** service to forward MPPS messages.

The maximum length PDU negotiation shall be included in all association establishments.

The SCU/SCP role negotiation is supported for storage commitment service.

Refer to the following paragraph for extensions, specializations, and privatizations management.

3.1.1.2 NUMBER OF ASSOCIATIONS

The number of simultaneous DICOM associations that is accepted is theoretically unlimited, but is actually limited by the Windows NT operating system. A new process or a new thread is created for each new association.

3.1.1.3 ASYNCHRONOUS NATURE

The DxServer AE does not support asynchronous communication (multiple outstanding transactions over a single association).

3.1.1.4 IMPLEMENTATION IDENTIFYING INFORMATION

By default, the DxServer Application Entity is identified by:

- Implementation Class UID: **1.2.250.1.38.1.3.1.1.1**
- Implementation Version Name: **DXS2_0**

3.1.2 ASSOCIATION INITIATION FOR DXSERVER AE

The DxServer AE initiates an association for the appropriate Storage SOP Class(es) that corresponds to the set of objects that have been requested for transfer. The association is closed when all objects have been sent to the remote DICOM AE.

Following the configuration, the DxServer AE will initiate an association for the Verification Services before responding to a routing request.

Following the configuration, the DxServer AE will initiate an association for the Storage Commitment Services after responding to a routing request.

Following the configuration, the DxServer AE will initiate an association for the MPPS Services to forward a MPPS message.

3.1.2.1 VERIFY COMMUNICATION WITH A REMOTE SYSTEM

The DxServer AE initiates an association for the echo service. The association is closed either when a correct response is received or when a time-out occurs.

3.1.2.1.1 ASSOCIATED REAL-WORLD ACTIVITY

The DxServer AE does not perform the routing or prefetching request if the DICOM Echo failed.

3.1.2.1.2 PROPOSED PRESENTATION CONTEXTS

DxServer supports the Verification SOP Class fully as specified in the DICOM Standard. The presentation context proposed by the DxServer AE for the Echo Check operation is specified in the following table:

Table 6: Echo Check Presentation Contexts of DxServer

Presentation Context Table					
Abstract Syntax		Transfer Syntax		Role	Extended Negotiation
Name	UID	Name	UID		
Verification SOP Class	1.2.840.10008.1.1	Implicit VR Little Endian	1.2.840.10008.1.2	SCU	None

3.1.2.1.3 SOP SPECIFIC CONFORMANCE

None.

3.1.2.2 SEND OBJECTS TO A REMOTE SYSTEM

The DxServer AE initiates associations for the transfer of objects to a DICOM Image Storage Server. The types of objects that can be transferred correspond to the SOP Classes listed in table 2.

3.1.2.2.1 ASSOCIATED REAL-WORLD ACTIVITY

The DxServer AE will initiate associations for the following reasons:

1. A C-MOVE request is received from a remote DICOM AE and an association is initiated to perform the C-STORE sub-operation.
2. DxBroker requests (routing or prefetching) that a set of objects be sent to a remote DICOM AE and an association is initiated to perform the C-STORE operation.

3.1.2.2.2 PROPOSED PRESENTATION CONTEXTS

DX SERVER FOR WINDOWS NT DICOM 3.0 CONFORMANCE STATEMENT

The presentation contexts that may be proposed by the DxServer AE for the Object operation are specified in table 5.

All these SOP classes conform to the standard Storage Services as specified in the DICOM Standard.

Table 7: Send Object Presentation Contexts of DxServer

Presentation Context Table					
Abstract Syntax		Transfer Syntax		Role	Extended Negotiation
Name	UID	Name	UID		
See Note	See Note	Implicit VR Little Endian	1.2.840.10008.1.2	SCU	None
		Explicit VR Little Endian	1.2.840.10008.1.2.1		
		Explicit VR Big Endian	1.2.840.10008.1.2.2		
		Explicit VR Little Endian, JPEG baseline encoded	1.2.840.10008.1.2.4.50		
		Explicit VR Little Endian, JPEG baseline encoded	1.2.840.10008.1.2.4.51		
		Explicit VR Little Endian, JPEG loss less encoded	1.2.840.10008.1.2.4.70		
		Explicit VR Little Endian, RLE loss less	1.2.840.10008.1.2.5		
Grayscale Softcopy Presentation State Storage	1.2.840.10008.5.1.4.1.1.11.1	Implicit VR Little Endian Explicit VR Little Endian	1.2.840.10008.1.2 1.2.840.10008.1.2.1	SCU	None
Key Object Selection Document	1.2.840.10008.5.1.4.1.1.88.59	Implicit VR Little Endian Explicit VR Little Endian	1.2.840.10008.1.2 1.2.840.10008.1.2.1	SCU	None
RT Dose Storage	1.2.840.10008.5.1.4.1.1.481.2	Implicit VR Little Endian Explicit VR Little Endian	1.2.840.10008.1.2 1.2.840.10008.1.2.1	SCU	None
RT Structure Set Storage	1.2.840.10008.5.1.4.1.1.481.3	Implicit VR Little Endian Explicit VR Little Endian	1.2.840.10008.1.2 1.2.840.10008.1.2.1	SCU	None
RT Beams Treatment Record Storage	1.2.840.10008.5.1.4.1.1.481.4	Implicit VR Little Endian Explicit VR Little Endian	1.2.840.10008.1.2 1.2.840.10008.1.2.1	SCU	None
RT Plan Storage	1.2.840.10008.5.1.4.1.1.481.5	Implicit VR Little Endian Explicit VR Little Endian	1.2.840.10008.1.2 1.2.840.10008.1.2.1	SCU	None
RT Brachy Treatment Record Storage	1.2.840.10008.5.1.4.1.1.481.6	Implicit VR Little Endian Explicit VR Little Endian	1.2.840.10008.1.2 1.2.840.10008.1.2.1	SCU	None
RT Summary Treatment Record Storage	1.2.840.10008.5.1.4.1.1.481.7	Implicit VR Little Endian Explicit VR Little Endian	1.2.840.10008.1.2 1.2.840.10008.1.2.1	SCU	None

Note: Include all abstract syntaxes from table 2, except those explicitly listed.

3.1.2.2.3 SOP SPECIFIC CONFORMANCE

DxServer preserves all private attributes that are encoded according to the DICOM Standard. Private attributes are always stored and are treated as Type 3 attributes. If a DICOM client of DxServer stores sends objects with private attributes using an Implicit VR, these attributes will be returned with an UN (unknown) VR in subsequent exports of this object when explicit VR is negotiated.

3.1.2.3 VERIFY THE COMMITTED STORAGE OF INSTANCES ON A REMOTE SYSTEM

When DxServer completes the transmission on instances for a routing request, it can optionally verify whether the instances have not only been received but also stored and committed successfully.

3.1.2.3.1 *PROPOSED PRESENTATION CONTEXTS*

DxServer supports the Storage Commitment Push Model SOP Class fully as specified in the DICOM Standard.

The presentation context proposed by the DxServer AE for the Storage Commitment operation is specified in the following table:

Table 8: Storage Commitment Push Model Presentation Contexts of DxServer

Presentation Context Table					
Abstract Syntax		Transfer Syntax		Role	Extended Negotiation
Name	UID	Name	UID		
Storage Commitment Push Model	1.2.840.10008.1.20.1	Implicit VR Little Endian	1.2.840.10008.1.2	SCU	None

3.1.2.3.2 *SOP SPECIFIC CONFORMANCE*

After the storage commitment request have been sent, DxServer will immediately close the association and will not wait for a reply from the SCP. Thus the N-EVENT-REPORT must occur on a different association than the N-ACTION command.

If a report is received, DxServer will check if the transmission was successful. If not, DxServer will retry the transmission (C-STORE and storage commitment) a configurable amount of few times. If it still fails, the routing request goes to an error state. If no report is received after a configurable time out, DxServer considers that the transmission was not successful.

On success, the routing request goes to a successful state.

3.1.2.4 FORWARD MPPS REQUESTS TO A REMOTE SYSTEM

When DxServer receives MPPS requests, it can optionally forward them to a remote system. Example, it receives MPPS from a modality and forwards to a RIS.

3.1.2.4.1 *PROPOSED PRESENTATION CONTEXTS*

DxServer supports the Modality Performed Procedure Step SOP Class fully as specified in the DICOM Standard.

The presentation context proposed by the DxServer AE for the MPPS operation is specified in the following table:

Table 9: Modality Performed Procedure Step Presentation Contexts of DxServer

Presentation Context Table					
Abstract Syntax		Transfer Syntax		Role	Extended Negotiation
Name	UID	Name	UID		
Modality Performed Procedure Step	1.2.840.10008.3.1.2.3.3	Implicit VR Little Endian	1.2.840.10008.1.2	SCU	None

3.1.2.4.2 SOP SPECIFIC CONFORMANCE

If transmission of N-CREATE or N-SET messages fails, DxServer will retry the transmission a configurable amount of few times. Messages with same MPP SOP Instance UID will be forwarded in the same order as they are received.

3.1.3 ASSOCIATION ACCEPTANCE POLICY FOR DXSERVER AE

The DxServer Application Entity accepts associations for the Verification Service, Storage Services, Query/Retrieve Services and Storage Commitment Service.

DxServer rejects association requests from application of which the AE Title is not registered within DxServer. The same applies to the case where the remote system uses a wrong AE Title to connect with DxServer.

An association is closed when there is no activity (i.e., no message received) for a configurable amount of time.

3.1.3.1 VERIFY COMMUNICATION WITH A REMOTE SYSTEM

The DxServer Application Entity waits for an association request and accepts associations to do, among other things, the Verification Service. The association is aborted if an error occurs and is closed when the initiator requests that it be closed.

3.1.3.1.1 ASSOCIATED REAL-WORLD ACTIVITY

DxServer performs an echo response after it receives a DICOM Echo request.

3.1.3.1.2 ACCEPTED PRESENTATION CONTEXTS

Only the presentation context listed in the following table will be accepted by DxServer for the Verification SOP Class.

Table 10: Echo Response Presentation Contexts of DxServer

Presentation Context Table					
Abstract Syntax		Transfer Syntax		Role	Extended Negotiation
Name	UID	Name	UID		
Verification SOP Class	1.2.840.10008.1.1	Implicit VR Little Endian	1.2.840.10008.1.2	SCP	None

3.1.3.1.3 SOP SPECIFIC CONFORMANCE

DxServer AE provides standard conformance to the DICOM Verification Service Class.

3.1.3.1.4 PRESENTATION CONTEXT ACCEPTANCE CRITERION

The shown presentation context above is always accepted.

3.1.3.2 RECEIVE OBJECTS FROM A REMOTE SYSTEM

The DxServer Application Entity waits for an association request and accepts associations to do, among other things, the Image Storage Service. The association is aborted if an error occurs and is closed when the initiator requests that it be closed.

3.1.3.2.1 ASSOCIATED REAL-WORLD ACTIVITY

Once the association has been established, the DxServer AE waits for transmission of conformant Storage Service messages. Objects received are decoded, most important attributes are stored in the database, and the file is store in a local folder

3.1.3.2.2 ACCEPTED PRESENTATION CONTEXTS

The presentation contexts that will be accepted by the DxServer AE for the Receive Object operation are listed in following table:

Table 11: Receive Object Presentation Contexts of DxServer

Presentation Context Table					
Abstract Syntax		Transfer Syntax		Role	Extended Negotiation
Name	UID	Name	UID		
See Note	See Note	Implicit VR Little Endian	1.2.840.10008.1.2	SCP	None
		Explicit VR Little Endian	1.2.840.10008.1.2.1		
		Explicit VR Big Endian	1.2.840.10008.1.2.2		
		Explicit VR Little Endian, JPEG baseline encoded	1.2.840.10008.1.2.4.50		
		Explicit VR Little Endian, JPEG baseline encoded	1.2.840.10008.1.2.4.51		
		Explicit VR Little Endian, JPEG loss less encoded	1.2.840.10008.1.2.4.70		
		Explicit VR Little Endian, RLE loss less	1.2.840.10008.1.2.5		
Grayscale Softcopy Presentation State Storage	1.2.840.10008.5.1.4.1.1.11.1	Implicit VR Little Endian	1.2.840.10008.1.2	SCP	None
		Explicit VR Little Endian	1.2.840.10008.1.2.1		
Key Object Selection Document	1.2.840.10008.5.1.4.1.1.88.59	Implicit VR Little Endian	1.2.840.10008.1.2	SCP	None
		Explicit VR Little Endian	1.2.840.10008.1.2.1		
RT Dose Storage	1.2.840.10008.5.1.4.1.1.481.2	Implicit VR Little Endian	1.2.840.10008.1.2	SCP	None
		Explicit VR Little Endian	1.2.840.10008.1.2.1		
RT Structure Set Storage	1.2.840.10008.5.1.4.1.1.481.3	Implicit VR Little Endian	1.2.840.10008.1.2	SCP	None
		Explicit VR Little Endian	1.2.840.10008.1.2.1		
RT Beams Treatment Record Storage	1.2.840.10008.5.1.4.1.1.481.4	Implicit VR Little Endian	1.2.840.10008.1.2	SCP	None
		Explicit VR Little Endian	1.2.840.10008.1.2.1		
RT Plan Storage	1.2.840.10008.5.1.4.1.1.481.5	Implicit VR Little Endian	1.2.840.10008.1.2	SCP	None
		Explicit VR Little Endian	1.2.840.10008.1.2.1		
RT Brachy Treatment Record Storage	1.2.840.10008.5.1.4.1.1.481.6	Implicit VR Little Endian	1.2.840.10008.1.2	SCP	None
		Explicit VR Little Endian	1.2.840.10008.1.2.1		
RT Summary Treatment Record Storage	1.2.840.10008.5.1.4.1.1.481.7	Implicit VR Little Endian	1.2.840.10008.1.2	SCP	None
		Explicit VR Little Endian	1.2.840.10008.1.2.1		

Note: Include all abstract syntaxes from table 2, except those explicitly listed.

3.1.3.2.3 SOP SPECIFIC CONFORMANCE

The DxServer AE conforms to the SOP's of the Storage SOP Class at Level 2 (Full). No elements are discarded or coerced by DxServer AE. In addition private attributes will be stored and included when the object is sent out again.

The DxServer AE responds to a C-STORE request with one of these response codes:

Table 12: C-STORE Response Codes

Service Status	Status Description	Status Code (0000,0900)	Related Fields
Refused	Out of Resources – There were insufficient resources to process the request. The request was not processed.	A765	(0000,0902) contains a short description of the condition.
Success		0000	None

3.1.3.2.4 PRESENTATION CONTEXT ACCEPTANCE CRITERION

The shown presentation context above is always accepted.

3.1.3.2.5 TRANSFER SYNTAX SELECTION POLICIES

The DxServer AE selects the first proposed transfer syntax as soon as it is compatible with table 7.

3.1.3.3 QUERY THE DX SERVER DATABASE AND RETRIEVE OBJECTS

The DxServer Application Entity waits for an association request and accepts associations to do, among other things, the DICOM Query/Retrieve Service. The association is closed after an error or when the initiator requests that it be closed.

3.1.3.3.1 ASSOCIATED REAL-WORLD ACTIVITY

Once the association has been established, DxServer waits for transmission of conformant Query Service messages. If a valid Find is received, then the DxServer database is searched and the requested information is returned to the Query SCU. If a valid Move request is received, then the DxServer database is searched for the requested objects and they are sent to the remote network node specified by the SCU. If a valid Get request is received, then the DxServer database is searched for the requested objects and they are sent to the SCU.

3.1.3.3.2 ACCEPTED PRESENTATION CONTEXTS

The presentation contexts that will be accepted by the DxServer AE for the Query/Retrieve operations are listed in following table:

Table 13: Query/Retrieve Response Presentation Contexts of DxServer

Presentation Context Table					
Abstract Syntax		Transfer Syntax		Role	Extended Negotiation
Name	UID	Name	UID		
Patient Root Query/Retrieve Model – FIND	1.2.840.10008.5.1.4.1.2.1.1	Implicit VR, Little Endian	1.2.840.10008.1.2	SCP	None
Patient Root Query/Retrieve Model – MOVE	1.2.840.10008.5.1.4.1.2.1.2	Implicit VR, Little Endian	1.2.840.10008.1.2	SCP	None
Patient Root Query/Retrieve Model – GET	1.2.840.10008.5.1.4.1.2.1.3	Implicit VR, Little Endian	1.2.840.10008.1.2	SCP	None
Study Root Query/Retrieve Model – FIND	1.2.840.10008.5.1.4.1.2.2.1	Implicit VR, Little Endian	1.2.840.10008.1.2	SCP	None
Study Root Query/Retrieve Model – MOVE	1.2.840.10008.5.1.4.1.2.2.2	Implicit VR, Little Endian	1.2.840.10008.1.2	SCP	None
Study Root Query/Retrieve Model – GET	1.2.840.10008.5.1.4.1.2.2.3	Implicit VR, Little Endian	1.2.840.10008.1.2	SCP	None

3.1.3.3.3 SOP SPECIFIC CONFORMANCE

DxServer supports only hierarchical queries.

DxServer supports the C-CANCEL request during a query operation.

The following table identifies the match support used by the DxServer AE. The values in this table indicate how the DxServer AE processes the received query attribute data.

Table 14: Matching Key Types

RV	Range Value match
SV	Single Value match
WC	Wild Card match
RET	Return value only

DxServer AE supports the following elements for Query/Retrieve service. DICOM attributes not listed in these tables are handled in that a zero-length attribute will be returned in response to a query for the specified attribute.

DX SERVER FOR WINDOWS NT DICOM 3.0 CONFORMANCE STATEMENT

Table 15: Supported keys for Patient Root Query/Retrieve

Level (0008,0052)	Description	Tag	Support
PATIENT	Patient's Name	(0010,0010)	WC
	Patient ID	(0010,0020)	WC
	Patient's Birth Date	(0010,0030)	RET
	Patient's Sex	(0010,0040)	RET
STUDY	Study Date	(0008,0020)	RV
	Study Time	(0008,0030)	RET
	Accession Number	(0008,0050)	WC
	Study ID	(0020,0010)	WC
	Study Instance UID	(0020,000D)	SV
	Modalities in Study ⁽¹⁾	(0008,0061)	SV
	Referring	(0008,0090)	RET
	Study Description	(0008,1030)	RET
	Number of Study Related Series	(0020,1206)	RET
	Number of Study Related Instances	(0020,1208)	RET
SERIES	Modality	(0008,0060)	SV
	Series Description	(0008,103E)	RET
	Body Part Examined	(0018,0015)	RET
	Series Number	(0020,0011)	SV
	Series Instance UID	(0020,000E)	SV
	Number of Series Related Instances	(0020,1209)	RET
COMPOSITE OBJECT INSTANCE	Instance Number	(0020,0060)	SV
	SOP Instance UID	(0008,0018)	SV
	SOP Class UID	(0008,0016)	RET
IMAGE SPECIFIC	Rows	(0028,0010)	RET
	Columns	(0028,0011)	RET
	Bits Allocated	(0028,0100)	RET
	Number of Frames	(0028,0008)	RET
GSPS SPECIFIC	Presentation Label	(0070,0080)	RET
	Presentation Description	(0070,0081)	RET
	Presentation Creation Date	(0070,0082)	RET
	Presentation Creation Time	(0070,0083)	RET
	Presentation Creator's Name	(0070,0084)	RET
KO SPECIFIC	Content Date	(0008,0023)	RET
	Content Time	(0008,0033)	RET
	Concept Name Code Sequence	(0040,A043)	RET
	Observation Date Time	(0040,A032)	RET

Table 16: Supported keys for Study Root Query/Retrieve

Level (0008,0052)	Description	Tag	Support
STUDY	Patient's Name	(0010,0010)	WC
	Patient ID	(0010,0020)	WC
	Patient's Birth Date	(0010,0030)	RET
	Patient's Sex	(0010,0040)	RET
	Study Date	(0008,0020)	RV
	Study Time	(0008,0030)	RET
	Accession Number	(0008,0050)	WC
	Study ID	(0020,0010)	WC
	Study Instance UID	(0020,000D)	SV
	Modalities in Study ⁽¹⁾	(0008,0061)	SV
	Referring	(0008,0090)	RET
	Study Description	(0008,1030)	RET
	Number of Study Related Series	(0020,1206)	RET
Number of Study Related Instances	(0020,1208)	RET	
SERIES	Modality	(0008,0060)	SV
	Series Description	(0008,103E)	RET
	Body Part Examined	(0018,0015)	RET
	Series Number	(0020,0011)	SV
	Series Instance UID	(0020,000E)	SV
	Number of Series Related Instances	(0020,1209)	RET
COMPOSITE OBJECT INSTANCE	Instance Number	(0020,0060)	SV
	SOP Instance UID	(0008,0018)	SV
	SOP Class UID	(0008,0016)	RET
IMAGE SPECIFIC	Rows	(0028,0010)	RET
	Columns	(0028,0011)	RET
	Bits Allocated	(0028,0100)	RET
	Number of Frames	(0028,0008)	RET
GSPS SPECIFIC	Presentation Label	(0070,0080)	RET
	Presentation Description	(0070,0081)	RET
	Presentation Creation Date	(0070,0082)	RET
	Presentation Creation Time	(0070,0083)	RET
	Presentation Creator's Name	(0070,0084)	RET
KO SPECIFIC	Content Date	(0008,0023)	RET
	Content Time	(0008,0033)	RET
	Concept Name Code Sequence	(0040,A043)	RET
	Observation Date Time	(0040,A032)	RET

(1) Modalities in Study: if the query contains multiple values, studies containing one of the modality listed will match.

C-FIND Response Codes

The DxServer AE responds to a C-FIND request with one of these response codes:

Table 17: C-FIND Response Codes

Service Status	Status Description	Status Code (0000,0900)	Related Fields
Refused	Out of Resources – There were insufficient resources to process the request. The request was not processed.	A700	(0000,0902) contains a short description of the condition.
Failed	Unable to Process – A condition arose which prevented the processing of the request.	C000	(0000,0902) contains a short description of the condition.
Cancel	Matching terminated – No more response messages will be sent as a result of a Cancel request from the SCU.	FE00	None
Success	Matching is complete – No final identifier is supplied	0000	None
Pending	Matches are continuing – Current match is supplied	FF00	Identifier
	Matches are continuing – Warning that one or more Optional Keys were not supported	FF01	Identifier

C-MOVE Response Codes

The DxServer AE responds to a C-MOVE request with one of these response codes:

Table 18: C-MOVE Response Codes

Service Status	Status Description	Status Code (0000,0900)	Related Fields*
Refused	Out of Resources – Unable to calculate number of matches	A701	(0000,0902)
	Out of Resources – Unable to perform sub-operations	A702	(0000,1020) (0000,1021) (0000,1022) (0000,1023)
	Move Destination unknown	A801	(0000,0902)
Failed	Identifier does not match SOP Class – A required attribute is not present in the message. The request was not processed.	A900	(0000,0902)
	Unable to Process – A condition arose which prevented the processing of the request.	C002	(0000,0902)
Cancel	Sub-operations terminated due to Cancel indication	FE00	(0000,1020) (0000,1021) (0000,1022) (0000,1023)
Warning	Sub-operations complete – One or more Failures were encountered	B000	(0000,1020) (0000,1021) (0000,1022) (0000,1023)
Success	Sub-operations complete – No Failure	0000	None
Pending	Sub-operations are continuing	FF00	(0000,1020) (0000,1021) (0000,1022) (0000,1023)

*Related fields:

(0000,0902): Contains a text description of the error detected.

(0000,1020): The number of remaining C-STORE sub-operation to be invoked for the operation.

(0000,1021): The number of C-STORE sub-operation associated with this operation which have been completed successfully.

(0000,1022): The number of C-STORE sub-operation associated with this operation which have failed.

(0000,1022): The number of C-STORE sub-operation associated with this operation which generated warning responses.

3.1.3.3.4 PRESENTATION CONTEXT ACCEPTANCE CRITERION

The shown presentation contexts above are always accepted.

3.1.3.4 COMMIT STORAGE OF IMAGES IN DxSERVER

The DxServer Application Entity waits for an association request and accepts associations to do, among other things, the DICOM Storage Commitment Service. The association is closed after an error or when the initiator requests that it be closed.

3.1.3.4.1 ASSOCIATED REAL WORLD ACTIVITY

DxServer can confirm the storage of instances on the local system when it is asked to do so.

3.1.3.4.2 ACCEPTED PRESENTATION CONTEXTS

The presentation contexts that will be accepted by the DxServer AE for the Storage Commitment operation are listed in following table:

Table 19: Storage Commitment Presentation Contexts of DxServer

Presentation Context Table					
Abstract Syntax		Transfer Syntax		Role	Extended Negotiation
Name	UID	Name	UID		
Storage Commitment Push Model	1.2.840.10008.1.20.1	Implicit VR, Little Endian	1.2.840.10008.1.2	SCP	SCU/SCP role

3.1.3.4.3 SOP SPECIFIC CONFORMANCE

While the SCU keeps the association alive, DxServer will send the N-EVENT-REPORT in the same association. While the initial association is alive, DxServer will first wait for a configurable interval (30 seconds by default). It will then verify periodically (same as interval) whether the requested objects are stored.

After the SCU closes the association, DxServer will open a new association to the SCU for transmitting the N-EVENT-REPORT response back to the storage commit inquirer. SCU/SCP role negotiation for storage commitment SOP class is included in the association negotiation. If the requested instances are stored on the system after a configurable time out, the N-EVENT-REPORT is sent back with a list of committed objects and a list of uncommitted objects.

DxServer does not support the optional Storage Media File-Set ID and UID attributes.

DxServer does not support the optional Retrieve AE Title.

3.1.3.4.4 PRESENTATION CONTEXT ACCEPTANCE CRITERION

The shown presentation context above is always accepted.

3.1.3.5 INFORM DXSERVER ABOUT PROCEDURE STEP

The DxServer Application Entity waits for an association request and accepts associations to do, among other things, the DICOM Modality Performed Procedure Step Service. The association is closed after an error or when the initiator requests that it be closed.

3.1.3.5.1 *ASSOCIATED REAL WORLD ACTIVITY*

Acquisition Modality informs DxServer that the procedure begins or finishes. The MPPS messages may also come from the RIS that forwards messages it receives.

3.1.3.5.2 *ACCEPTED PRESENTATION CONTEXTS*

The presentation contexts that will be accepted by the DxServer AE for the MPPS operation are listed in following table:

Table 20: Modality Performed Procedure Step Presentation Contexts of DxServer

Presentation Context Table					
Abstract Syntax		Transfer Syntax		Role	Extended Negotiation
Name	UID	Name	UID		
Modality Performed Procedure Step	1.2.840.10008.3.1.2.3.3	Implicit VR, Little Endian	1.2.840.10008.1.2	SCP	None

3.1.3.5.3 *SOP SPECIFIC CONFORMANCE*

For a given MPPS SOP instance UID, DxServer must receive first a N-CREATE, all N-SET receives before N-CREATE are rejected.

For a given MPPS SOP instance UID, only one N-CREATE is accepted, the status must 'IN PROGRESS'.

For a given MPPS SOP instance UID, no other N-SET are accepted after a status 'COMPLETED' or 'DISCONTINUED'.

Following the configuration, DxServer may use N-SET message with status 'COMPLETED' to set the study status to 'COMPLETED' when all instances listed in the referenced image sequence are received.

Following the IHE recommendations about PPS exception management, when a PPS DISCONTINUED is received with the reason code "wrong worklist entry selected", images referenced in this PPS DISCONTINUED are deleted. The images can be received before or after the reception of the PPS DISCONTINUED.

DX SERVER FOR WINDOWS NT DICOM 3.0 CONFORMANCE STATEMENT

DxServer AE uses the following attributes of MPPS messages. All attributes are forwarded.

Table 21: MPPS Attributes

Description / Module	Tag	Req. C: N- CREATE S: N-SET	Key Type
SOP Common			
Specific Character Set	(0008,0005)	C,S	1C
MPPS SOP Instance UID	(0000,1000)	C,S	1
Performed Procedure Step Relationship			
Scheduled Step Attribute Sequence	(0040,0270)	C	1
>Study Instance UID	(0020,000D)	C	1
Performed Procedure Step Information			
Performed Procedure Step Status	(0040,0252)	C,S	1
Performed Procedure Step Discontinuation Reason Code Sequence	(0040,0281)	S	
>Code Value	(0008,0100)	S	
>Coding Scheme Designator	(0008,0102)	S	
>Code Meaning	(0008,0104)	S	
Image Acquisition Results			
Performed Series Sequence	(0040,0340)	C,S	2,1
>Series Instance UID	(0020,000E)	C,S	1 ⁽¹⁾
>Referenced Image Sequence	(0008,1140)	C,S	2
>>Referenced SOP Class UID	(0008,1150)	C,S	1 ⁽¹⁾
>>Referenced SOP Instance UID	(0008,1155)	C,S	1 ⁽¹⁾

(1): Required if Sequence Item is present

N-CREATE/N-SET Response Codes

The DxServer AE responds to a N-CREATE or N-SET request with one of these response codes:

Table 22: MPPS Response Codes

Service Status	Status Description	Status Code (0000,0900)	Related Fields
Refused	N-CREATE missing attribute – a mandatory attribute is missing in the message	0120	(0000,0902) contains a short description of the condition.
	N-CREATE duplicate SOP instance – N-CREATE message with same SOP instance UID have been received.	0111	(0000,0902) contains a short description of the condition.
	N-SET no such SOP instance – N-CREATE has not been received.	0112	(0000,0902) contains a short description of the condition
Failed	Unable to Process – A condition arose which prevented the processing of the request.	C000	(0000,0902) contains a short description of the condition.
Success		0000	None

3.1.3.5.4 PRESENTATION CONTEXT ACCEPTANCE CRITERION

The shown presentation context above is always accepted.

3.2 DXBROKER AE SPECIFICATIONS

Verification SOP Class

The **DxBroker AE** provides standard conformance to the following DICOM V3.0 Service Object Pair (SOP) Class as a Verification Service Class Provider (SCP). As an SCP it sends an Echo response when it receives an Echo request from a remote AE.

Table 23: Valid SCP Verification SOP Class for DxBroker AE

SOP Class UID	SOP Class Name
1.2.840.10008.1.1	Verification SOP Class

Basic Modality Worklist SOP Class

The **DxBroker AE** provides standard conformance to the following DICOM V3.0 Service Object Pair (SOP) Class as a Basic Modality Worklist Class Provider (SCP), when servicing queries about scheduled procedure steps.

Table 24: Valid SCP Basic Modality Worklist SOP Class for DxBroker AE

SOP Class UID	SOP Class Name
1.2.840.10008.5.1.4.31	Basic Modality Worklist SOP Class

3.2.1 ASSOCIATION ESTABLISHMENT POLICIES FOR DXBROKER AE

3.2.1.1 GENERAL

All associations with the **DxBroker AE** shall be established using the DICOM 3.0 Application Context. A single DICOM Application Context Name is defined for this version of the DICOM standard. This name is “**1.2.840.10008.3.1.1.1**”.

The **DxBroker AE** accepts association for the following purposes:

- Supports the **C-ECHO** service to allow end-to-end verifications.
- Supports the **Basic Modality Worklist** service to query the scheduled procedure steps.
-

The **DxServer AE** does not initiate association.

The maximum length PDU negotiation shall be included in all association establishments.

The SCU/SCP role negotiation is not supported.

Refer to the following paragraph for extensions, specializations, and privatizations management.

3.2.1.2 NUMBER OF ASSOCIATIONS

The number of simultaneous DICOM associations that is accepted is theoretically unlimited, but is actually limited by the Windows NT operating system. A new process is created for each new association.

3.2.1.3 ASYNCHRONOUS NATURE

The DxBroker AE does not support asynchronous communication (multiple outstanding transactions over a single association).

3.2.1.4 IMPLEMENTATION IDENTIFYING INFORMATION

By default, the DxBroker Application Entity is identified by:

- Implementation Class UID: **1.2.250.1.38.1.3.1.1.1**
- Implementation Version Name: **DXWORK1_1**

3.2.2 **ASSOCIATION INITIATION FOR DxBROKER AE**

Not applicable.

3.2.3 **ASSOCIATION ACCEPTANCE POLICY FOR DxBROKER AE**

The DxBroker Application Entity accepts associations for the Verification Service and Basic Modality Worklist Services.

DxBroker rejects association requests from application of which the AE Title is not registered within DxBroker. The same applies to the case where the remote system uses a wrong AE Title to connect with DxBroker.

An association is closed when there is no activity (i.e., no message received) for a configurable amount of time.

3.2.3.1 VERIFY COMMUNICATION WITH A REMOTE SYSTEM

The DxBroker Application Entity waits for an association request and accepts associations to do, among other things, the Verification Service. The association is aborted if an error occurs and is closed when the initiator requests that it be closed.

3.2.3.1.1 ASSOCIATED REAL-WORLD ACTIVITY

DxBroker performs an echo response after it receives a DICOM Echo request.

3.2.3.1.2 ACCEPTED PRESENTATION CONTEXTS

Only presentation context listed in the following table will be accepted by DxBroker for the Verification SOP Class.

Table 25: Echo Response Presentation Contexts of DxBroker

Presentation Context Table					
Abstract Syntax		Transfer Syntax		Role	Extended Negotiation
Name	UID	Name	UID		
Verification SOP Class	1.2.840.10008.1.1	Implicit VR Little Endian	1.2.840.10008.1.2	SCP	None

3.2.3.1.3 SOP SPECIFIC CONFORMANCE TO VERIFICATION SOP CLASS

DxBroker AE provides standard conformance to the DICOM Verification Service Class.

3.2.3.1.4 PRESENTATION CONTEXT ACCEPTANCE CRITERION

The shown presentation context above is always accepted.

3.2.3.2 QUERY THE DX BROKER WORK LIST

The DxBroker Application Entity waits for an association request and accepts associations to do, among other things, the Basic DICOM Worklist Service. The association is closed after an error or when initiator requests that it be closed.

3.2.3.2.1 *ASSOCIATED REAL-WORLD ACTIVITY*

Once the association has been established, DxBroker waits for transmission of conformant Query Service messages. If a valid Find is received, then the DxBroker work list is searched and the requested information is returned to the Query SCU.

Table 26: Modality Worklist Response Presentation Contexts of DxBroker

Presentation Context Table					
Abstract Syntax		Transfer Syntax		Role	Extended Negotiation
Name	UID	Name	UID		
Modality Worklist C-FIND	1.2.840.10008.5.1.4.31	Implicit VR, Little Endian	1.2.840.10008.1.2	SCP	None

3.2.3.2.2 *SOP SPECIFIC CONFORMANCE*

DxBroker supports the C-CANCEL request during a query operation.

The following table identifies the match support used by the DxBroker AE. The values in this table indicate how the DxBroker AE processes the received query attribute data.

Table 27: Matching Key Types

RV	Range Value match
SV	Single Value match
WC	Wild Card match
RET	Return value only

DxBroker AE supports the following elements for the MWL SOP class. DICOM attributes not listed in this table are handled in that a zero-length attribute will be returned in response to a query for the specified attribute.

Table 28: Supported keys for MWL Query

MWL Attributes			
Description / Module	Tag	Matching Key Type	Return Key Type
Scheduled Procedure Step			
Scheduled Procedure Step Sequence	(0040,0100)		1
>Scheduled Station AE Title	(0040,0001)	SV	1
>Scheduled Procedure Step Start Date	(0040,0002)	SV, RV	1
>Scheduled Procedure Step Start Time	(0040,0003)	SV,RV	1
>Scheduled Procedure Step Location	(0040,0011)	RET	2
>Modality	(0008,0060)	SV	1
>Scheduled Performing Physician's Name	(0040,0006)	RET	2
>Scheduled Procedure Step Description	(0040,0007)	RET	1C
>Scheduled Station Name	(0040,0010)	RET	2
>Scheduled Procedure Step ID	(0040,0009)	RET	1
>Scheduled Protocol Code Sequence	(0040,0008)	RET	1C
>>Code Value	(0008,0100)	RET	1C
>>Coding Scheme Designator	(0008,0102)	RET	1C
>>Code Meaning	(0008,0104)	RET	3
Requested Procedure			
Requested Procedure ID	(0040,1001)	SV	1
Requested Procedure Description	(0032,1060)	RET	1C
Requested Procedure Code Sequence	(0032,1064)	RET	1C
>>Code Value	(0008,0100)	RET	1C
>>Coding Scheme Designator	(0008,0102)	RET	1C
>>Code Meaning	(0008,0104)	RET	3
Study Instance UID	(0020,000D)	RET	1
Referenced Study Sequence	(0008,1110)	RET	2
>Referenced SOP Class UID	(0008,1150)	RET	1C
>Referenced SOP Instance UID	(0008,1155)	RET	1C
Patient Transport Arrangements	(0040,1004)	RET	2
Imaging Service Request			
Accession Number	(0008,0050)	SV	2
Requesting Physician	(0032,1032)	RET	2
Requesting Service	(0032,1033)	RET	3
Requesting Physician's Name	(0008,0090)	RET	2
Visit Identification			
Admission ID	(0038,0010)	RET	2
Visit Status			
Current Patient Location	(0038,0300)	RET	2
Patient Identification			
Patient's Name	(0010,0010)	SV, WC	1
Patient ID	(0010,0020)	SV	1
Patient Demographic			
Patient's Birth Date	(0010,0030)	RET	2
Patient's Sex	(0010,0040)	RET	2
Confidentiality constraint on patient data	(0040,3001)	RET	2
Patient Medical			
Patient State	(0038,0500)	RET	2
Pregnancy Status	(0010,21C0)	RET	2
Contrast Allergies	(0010,2110)	RET	2
Patient's Weight	(0010,1030)	RET	2

Special Needs	(0038,0050)	RET	2
---------------	-------------	-----	---

Table 29: MWL C-FIND Response Codes

Service Status	Status Description	Status Code (0000,0900)	Related Fields
Refused	Out of Resources – There were insufficient resources to process the request. The request was not processed.	A700	(0000,0902) contains a short description of the condition.
Failed	Unable to Process – A condition arose which prevented the processing of the request.	C000	(0000,0902) contains a short description of the condition
Cancel	Matching terminated – No more response messages will be sent as a result of a Cancel request from the SCU.	FE00	None
Success	Matching is complete – No final identifier is supplied	0000	None
Pending	Matches are continuing – Current match is supplied	FF00	Identifier
	Matches are continuing – Warning that one or more Optional Keys were not supported	FF01	Identifier

MWL Search Constraints

The MWL search is a function of the criterion (data attributes) specified in the incoming C-FIND. The MWL SCP does not apply any default constraints on an incoming query, with the exception of the following:

1. If the incoming query is a time range with no date constraint, the current date will be used as the date constraint and the time range query will be executed under the current (today's) date.
2. For time ranges, '000000' substitutes a missing lower bound and '235959' substitutes the missing upper bound.
3. If the incoming query is a time and date range, the time range is ignored if the date range is over more than one day.

4 COMMUNICATION PROFILES

4.1 SUPPORTED COMMUNICATIONS STACKS

DxServer provides DICOM V3.0 TCP/IP Network Communication Support as defined in PS 3.8.

4.2 TCP/IP STACK

DxServer inherits the TCP/IP stack from the MS Windows system upon which it executes.

4.3 PHYSICAL MEDIA SUPPORT

DxServer is indifferent to the physical medium over which TCP/IP executes; they inherit this from the MS Windows system upon which they execute.

5 EXTENSIONS / SPECIALIZATIONS / PRIVATIZATIONS

No extended, specialized or private SOP classes are supported.

No private transfer syntaxes are supported.

6 CONFIGURATION

See [1] for full details.

7 SUPPORT OF EXTENDED CHARACTER SETS

DxServer supports the following character sets:

Table 30: Character sets

Code Element	Description
ISO-IR 6	Default character set
ISO-IR 100	Latin alphabet n°1
ISO-IR 13	Japanese katakana (phonetic) characters (94 characters)
ISO-IR 87	Japanese kanji (ideographic), hiragana (phonetic), and katakana (phonetic) characters (94 ² characters, 2-byte)

8 SECURITY

8.1 SECURITY PROFILES

Dx Server supports secure DICOM communication in conformance with the Basic TLS Secure Transport Connection Profile. This support is an option of the installation setup and can be disabled.

8.2 ASSOCIATION LEVEL SECURITY

By default, Dx Server accepts association requests from only registered calling AE Titles. This behavior can be disabled in configuration file by an administrator.

8.3 APPLICATION LEVEL SECURITY

Dx Server requires user authentication in order to access to the user interface functionalities. The user must be an administrator (defined in Dx Server).