

	NAME	FONCTION	VISA
AUTHOR	Alain Battistini	Senior Engineer	CONFORM TO ORIGINAL
REVIEW	Jean-François Hoh	Senior Engineer	CONFORM TO ORIGINAL
APPROVAL	Pascal Gilbert-Jeantet		CONFORM TO ORIGINAL

Revision History

Revision	Date	Who	Change
A	30-Oct-00	ABA	Creation for Dx MM 4.1
B	31-Oct-00	ABA	Updated for Dx MM 4.2
C	13-Feb-03	ABA	Added Media Storage
D	04-Apr-04	ABA	Added Security

Table of Contents

1	Introduction	3
1.1	Scope and audience	3
1.2	References	3
1.3	Acronyms and abbreviations	3
2	Implementation model.....	4
2.1	Application data flow diagram	4
2.1.1	Respond to verification requests	4
2.2	Functional definition of Application Entities	5
2.3	Sequencing of Real World Activities	5
3	Application Entity specifications	5
3.1	DxMM AE Specifications	5
3.1.1	Association establishment policies for DxMM AE	6
3.1.1.1	General	6
3.1.1.2	Number of associations	7
3.1.1.3	Asynchronous nature	7
3.1.1.4	Implementation identifying information	7
3.1.2	Association initiation for DxMM AE	7
3.1.2.1	Verify Communication with a Remote System	7

3.1.2.1.1	Associated real-world activity	7
3.1.2.1.2	Proposed Presentation Contexts	8
3.1.2.1.3	SOP specific conformance	8
3.1.2.2	Send Objects to a Remote System	8
3.1.2.2.1	Associated real-world activity	8
3.1.2.2.2	Proposed Presentation Contexts	8
3.1.2.2.3	SOP specific conformance	9
3.1.2.3	Query remote database and retrieve images	9
3.1.2.3.1	Associated real-world activity	9
3.1.2.3.2	Proposed Presentation Contexts	9
3.1.2.3.3	SOP Specific Conformance	10
3.1.2.4	Print to a remote Imager	11
3.1.2.4.1	Associated real-world activity	11
3.1.2.4.2	Proposed Presentation Contexts	11
3.1.2.4.3	SOP Specific Conformance for Basic Grayscale and Color Print Management Meta SOP classes	12
3.1.2.4.4	SOP Specific Conformance Statement for SOP Class Print Job	14
3.1.3	Association acceptance policy for DxMM AE	15
3.1.3.1	Verify Communication with a Remote System	15
3.1.3.1.1	Associated real-world activity	15
3.1.3.1.2	Accepted Presentation Contexts	15
3.1.3.1.3	SOP Specific Conformance	15
3.1.3.1.4	Presentation Context Acceptance Criterion	15
3.1.3.2	Receive Objects from a Remote System	15
3.1.3.2.1	Associated real-world activity	15
3.1.3.2.2	Accepted Presentation Contexts	16
3.1.3.2.3	SOP Specific Conformance	16
3.1.3.2.4	Presentation context acceptance criterion	16
3.1.3.2.5	Transfer syntax selection policies	16
3.2	DxMM Media Storage AE	17
3.2.1	Real-world activity: Display Directory of CD-R disk	18
3.2.2	Real-world activity: Read images from CD-R disk	18
3.2.3	Real-world activity: Write images	18
4	Communication Profiles	20
4.1	Supported Communications Stacks	20
4.2	TCP/IP Stack	20
4.3	Physical Media Support	20
5	Extensions / Specializations / Privatizations	20
6	Configuration.....	20
7	Support of extended character sets.....	20

1 INTRODUCTION

1.1 SCOPE AND AUDIENCE

This document is a DICOM Conformance Statement Dx MM. The purpose of this document is to describe how Dx MM collaborates in a DICOM network with other Medical Imaging applications that conform to the DICOM 3.0 standard.

This document has been written using the guidelines provided in the DICOM standard [2 – part 2].

Note: The French ISO member body AFNOR has provided Medasys Digital Systems with an UID root. This UID root is only in numerical form as following: 1.2.250.1.38

1.2 REFERENCES

- [1] Dx MM reference Manual
- [2] ACR/NEMA Standards Publications, No PS3, DICOM Standards:
 - Part 1 - Introduction
 - Part 2 - Conformance
 - Part 3 - Information Object Definitions
 - Part 4 - Service Class Specifications
 - Part 5 - Data Structures and Encoding
 - Part 6 - Data Dictionary
 - Part 7 - Message Exchange
 - Part 8 - Network Communication Support
 - Part 9 - Point to Point Communication Support for Message Exchange
 - Part 10 - Media Storage and File Format for Media Interchange
 - Part 11 - Media Storage Application Profiles
 - Part 12 - Storage Functions and Media Formats for Data Interchange
 - Part 13 - Print Management Point-to-Point Communication Support

1.3 ACRONYMS AND ABBREVIATIONS

The following symbols and abbreviations are used in this conformance statement:

ACR:	American College of Radiology
AE:	DICOM Application Entity
DICOM:	Digital Imaging and Communication in Medicine
DIMSE:	DICOM Message Service Element
FSC:	File Set Creator
FSR:	File Set Reader
FSU:	File Set Updater
IOD:	DICOM Information Object Definition

ISO:	International Standard Organization
NEMA:	National Electrical Manufacturers Association
PDU:	DICOM Protocol Data Unit
SCP:	DICOM Service Class Provider
SCU:	DICOM Service Class User
SOP:	DICOM Service-Object Pair
TCP/IP:	Transmission Control Protocol / Internet Protocol
UID:	Unique Identifier
VR:	Value Representation

2 IMPLEMENTATION MODEL

The primary functions provided by DxMM are:

1. Query and Retrieve objects from a remote device
2. Accept objects from a DICOM storage service class user and store object in a DICOMDIR
3. Print on a DICOM printer

2.1 APPLICATION DATA FLOW DIAGRAM

2.1.1 RESPOND TO VERIFICATION REQUESTS

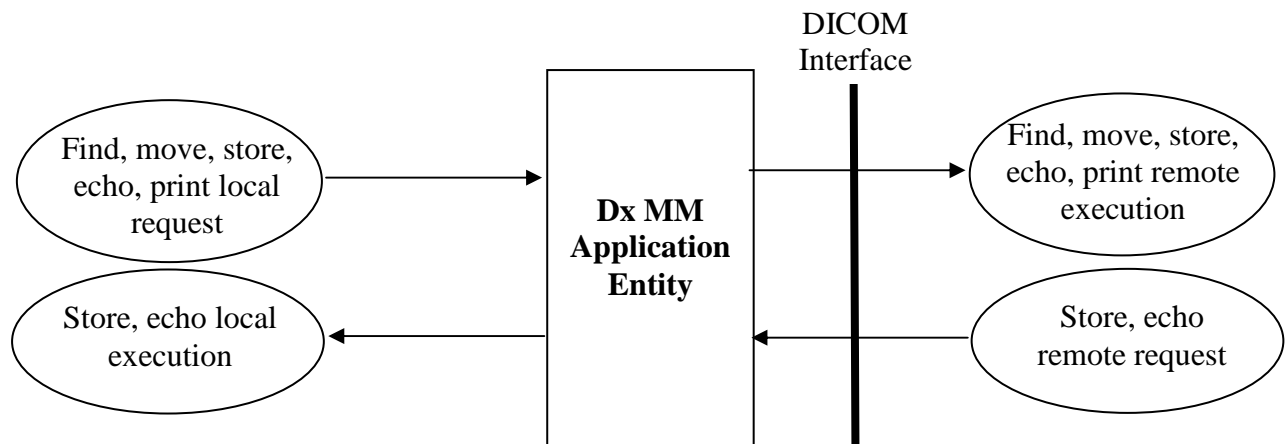

2.2 FUNCTIONAL DEFINITION OF APPLICATION ENTITIES

DxMM application entity acts as a Service Class Provider (SCU) for the following service classes:

- Verification Service Class
- Storage Service Class
- Query/Retrieve Service Class
- Print Service Class

DxMM application entity acts as a Service Class User (SCP) for the following service classes:

- Verification Service Class
- Storage Service Class

2.3 SEQUENCING OF REAL WORLD ACTIVITIES

Not applicable.

3 APPLICATION ENTITY SPECIFICATIONS

3.1 DxMM AE SPECIFICATIONS

Verification SOP Class

The **DxMM** AE provides standard conformance to the following DICOM V3.0 Service Object Pair (SOP) Class as a Verification Service Class User (SCU) and Provider (SCP). As an SCU it sends an Echo request to check remote AE. As an SCP it sends an Echo response when it receives an Echo request from a remote AE.

Table 1: Valid SCU/SCP Verification SOP Class for DxMM AE

SOP Class UID	SOP Class Name
1.2.840.10008.1.1	Verification SOP Class

Storage SOP Classes

The **DxMM** AE provides standard conformance to the following DICOM V3.0 SOP Classes as an SCP when retrieving objects. It also supports these SOP Classes as an SCU when storing object on a remote AE.

Table 2: Valid SCU/SCP Storage SOP Classes for DxMM AE

SOP Class UID	SOP Class Name
1.2.840.10008.5.1.4.1.1.1	Computed Radiography Image Storage
1.2.840.10008.5.1.4.1.1.1.1	Digital X-Ray Image Storage – For Presentation
1.2.840.10008.5.1.4.1.1.1.2	Digital Mammography X-Ray Image Storage – For Presentation
1.2.840.10008.5.1.4.1.1.2	CT Image Storage
1.2.840.10008.5.1.4.1.1.3	Ultrasound Multi-frame Image Storage (retired)
1.2.840.10008.5.1.4.1.1.3.1	Ultrasound Multi-frame Image Storage
1.2.840.10008.5.1.4.1.1.4	MR Image Storage
1.2.840.10008.5.1.4.1.1.5	Nuclear Medicine Image Storage (retired)
1.2.840.10008.5.1.4.1.1.6	Ultrasound Image Storage (retired)
1.2.840.10008.5.1.4.1.1.6.1	Ultrasound Image Storage
1.2.840.10008.5.1.4.1.1.7	Secondary Capture Image Storage
1.2.840.10008.5.1.4.1.1.12.1	X-Ray Angiographic Image Storage

1.2.840.10008.5.1.4.1.1.12.2	X-Ray Radiflouroscopic Image Storage
1.2.840.10008.5.1.4.1.1.12.3	X-Ray Angiographic Bi-plane Image Storage
1.2.840.10008.5.1.4.1.1.20	Nuclear Medicine Image Storage
1.2.840.10008.5.1.4.1.1.128	Positron Emission Tomography (PET) Image Storage
1.2.840.10008.5.1.4.1.1.481.1	Radiotherapy (RT) Image Storage

Query/Retrieve SOP Classes

The **DxMM** AE provides standard conformance to the following DICOM V3.0 SOP Classes as a Query/Retrieve SCU, when user browses and retrieves objects located on a remote AE.

Table 3: Valid SCU Query/Retrieve SOP Class for DxMM AE

SOP Class UID	SOP Class Name
1.2.840.10008.5.1.4.1.2.1.1	Patient Root Query/Retrieve Information Model – Find
1.2.840.10008.5.1.4.1.2.1.2	Patient Root Query/Retrieve Information Model – Move
1.2.840.10008.5.1.4.1.2.1.3	Patient Root Query/Retrieve Information Model – Get
1.2.840.10008.5.1.4.1.2.2.1	Study Root Query/Retrieve Information Model – Find
1.2.840.10008.5.1.4.1.2.2.2	Study Root Query/Retrieve Information Model – Move
1.2.840.10008.5.1.4.1.2.2.3	Study Root Query/Retrieve Information Model – Get

Print Management (Meta) SOP Class

The **DxMM** AE provides standard conformance to the following DICOM V3.0 Service Object Pair (SOP) Classes as a SCU when user prints films on a remote DICOM printer.

Table 4: Valid SCU Print Management (Meta) SOP Class for DxMM AE

SOP Class UID	SOP Class Name
1.2.840.10008.5.1.1.9	Basic Grayscale Print Management Meta SOP Class
1.2.840.10008.5.1.1.18	Basic Color Print Management Meta SOP Class
1.2.840.10008.5.1.1.1	Basic Film Session SOP Class
1.2.840.10008.5.1.1.2	Basic Film Box SOP Class
1.2.840.10008.5.1.1.4	Basic Grayscale Image Box SOP Class
1.2.840.10008.5.1.1.4.1	Basic Color Image Box SOP Class
1.2.840.10008.5.1.1.14	Print Job SOP Class
1.2.840.10008.5.1.1.16	Printer SOP Class
1.2.840.10008.5.1.1.29	Hardcopy Grayscale Image Storage SOP Class
1.2.840.10008.5.1.1.30	Hardcopy Color Image Storage SOP Class
1.2.840.10008.5.1.1.16.376	Printer Configuration Retrieval SOP Class

3.1.1 ASSOCIATION ESTABLISHMENT POLICIES FOR DXMM AE

3.1.1.1 GENERAL

All associations with the DxMM AE shall be established using the DICOM 3.0 Application Context. A single DICOM Application Context Name is defined for this version of the DICOM standard. This name is “**1.2.840.10008.3.1.1.1**”.

The DxMM AE initiates association for the following purposes:

- Invokes the **C-ECHO** service to allow end-to-end verifications.
- Invokes the **C-STORE** service to store objects into a remote database.
- Invokes the **C-FIND** service to query a remote database.
- Invokes the **C-MOVE** service to retrieve or forward images from a remote database.
- Invokes the **C-GET** service to retrieve images from a remote database.

- Invokes the **Basic Grayscale** or **Color Print Management** service to print images to a remote printer.

The DxMM AE accepts associations for the following purposes:

- Accepts the **C-STORE** service to receives images, as sub-operations of a C-MOVE service request, or when a remote system pushes images to DxMM AE.
- Accepts the **C-ECHO** service to allow end-to-end verifications.

The maximum length PDU negotiation shall be included in all association establishments.

The SCU/SCP role negotiation is not supported.

Refer to the following paragraph for extensions, specializations, and privatizations management.

3.1.1.2 NUMBER OF ASSOCIATIONS

The number of simultaneous DICOM associations that is accepted for a C-STORE push is theoretically unlimited, but is actually limited by the Windows NT operating system. A new process or a new thread is created for each new association.

3.1.1.3 ASYNCHRONOUS NATURE

The DxMM AE does not support asynchronous communication (multiple outstanding transactions over a single association).

3.1.1.4 IMPLEMENTATION IDENTIFYING INFORMATION

By default, the DxMM Application Entity is identified by:

- Implementation Class UID: **1.2.250.1.38.1.3.1.1.1**
- Implementation Version Name: **DXS2_0**

3.1.2 ASSOCIATION INITIATION FOR DXMM AE

The DxMM AE initiates associations for the purpose of:

- communication verification,
- image transfers to a remote database,
- image retrieval from a remote database,
- image forwarding (migration) from a remote database to a third application acting as a DICOM server,
- image printing to a remote printer.

3.1.2.1 VERIFY COMMUNICATION WITH A REMOTE SYSTEM

3.1.2.1.1 ASSOCIATED REAL-WORLD ACTIVITY

The DxMM AE initiates an association for the echo service in order to get information about their possibilities. The association is closed either when a correct response is received or when a time-out occurs.

The DxMM AE can perform C-ECHO at the beginning of each Q/R session (configurable) or when the user wants to test the DICOM communication.

3.1.2.1.2 PROPOSED PRESENTATION CONTEXTS

DxMM supports the Verification SOP Class fully as specified in the DICOM Standard. The presentation context proposed by the DxMM AE for the Echo Check operation is specified in the following table:

Table 5: Echo Check Presentation Contexts of DxMM

Presentation Context Table					
Abstract Syntax		Transfer Syntax		Role	Extended Negotiation
Name	UID	Name	UID		
Verification SOP Class	1.2.840.10008.1.1	Implicit VR Little Endian	1.2.840.10008.1.2	SCU	None

3.1.2.1.3 SOP SPECIFIC CONFORMANCE

None.

3.1.2.2 SEND OBJECTS TO A REMOTE SYSTEM

3.1.2.2.1 ASSOCIATED REAL-WORLD ACTIVITY

The DxMM AE initiates associations for the transfer of objects to a DICOM Image Storage Server. The types of objects that can be transferred correspond to the SOP Classes listed in table 2.

The DxMM AE will initiate associations for the following reasons:

1. Save images on a remote DICOM AE.
2. Transfer images from one source to a remote DICOM AE.

3.1.2.2.2 PROPOSED PRESENTATION CONTEXTS

The presentation contexts that may be proposed by the DxMM AE for the Object operation are specified in table 2.

All these SOP classes conform to the standard Storage Services as specified in the DICOM Standard.

Table 6: Send Object Presentation Contexts of DxMM

Presentation Context Table					
Abstract Syntax		Transfer Syntax		Role	Extended Negotiation
Name	UID	Name	UID		
See Note	See Note	Implicit VR Little Endian	1.2.840.10008.1.2	SCU	None
		Explicit VR Little Endian	1.2.840.10008.1.2.1		
		Explicit VR Big Endian	1.2.840.10008.1.2.2		
		Explicit VR Little Endian, JPEG baseline encoded	1.2.840.10008.1.2.4.50		
		Explicit VR Little Endian, JPEG baseline encoded	1.2.840.10008.1.2.4.51		
		Explicit VR Little Endian, JPEG loss less encoded	1.2.840.10008.1.2.4.70		
		Explicit VR Little Endian, RLE loss less	1.2.840.10008.1.2.5		

Note: Include all abstract syntaxes from table 2

3.1.2.2.3 SOP SPECIFIC CONFORMANCE

DxMM preserves all private attributes that are encoded according to the DICOM Standard. Private attributes are always stored and are treated as Type 3 attributes. If a DICOM client of DxMM stores sends objects with private attributes using an Implicit VR, these attributes will be returned with an UN (unknown) VR in subsequent exports of this object when explicit VR is negotiated.

3.1.2.3 QUERY REMOTE DATABASE AND RETRIEVE IMAGES

3.1.2.3.1 ASSOCIATED REAL-WORLD ACTIVITY

DxMM AE initiates associations to remote systems in order to query from those systems image information using the C-FIND DIMSE-C service, and retrieve the images using the C-MOVE or C-GET DIMSE-C service.

3.1.2.3.2 PROPOSED PRESENTATION CONTEXTS

DxMM supports the Query/Retrieve SOP Class fully as specified in the DICOM Standard. The presentation contexts proposed by the DxMM AE for the Query/Retrieve operations are specified in the following table:

Table 7: Query/Retrieve Presentation Contexts of DxMM

Presentation Context Table					
Abstract Syntax		Transfer Syntax		Role	Extended Negotiation
Name	UID	Name	UID		
Patient Root Query/Retrieve Model – FIND	1.2.840.10008.5.1.4.1.2.1.1	Implicit VR, Little Endian	1.2.840.10008.1.2	SCU	None
Patient Root Query/Retrieve Model – MOVE	1.2.840.10008.5.1.4.1.2.1.2	Implicit VR, Little Endian	1.2.840.10008.1.2	SCU	None
Patient Root Query/Retrieve Model – GET	1.2.840.10008.5.1.4.1.2.1.3	Implicit VR, Little Endian	1.2.840.10008.1.2	SCU	None
Study Root Query/Retrieve Model – FIND	1.2.840.10008.5.1.4.1.2.2.1	Implicit VR, Little Endian	1.2.840.10008.1.2	SCU	None
Study Root Query/Retrieve Model – MOVE	1.2.840.10008.5.1.4.1.2.2.2	Implicit VR, Little Endian	1.2.840.10008.1.2	SCU	None
Study Root Query/Retrieve Model – GET	1.2.840.10008.5.1.4.1.2.2.3	Implicit VR, Little Endian	1.2.840.10008.1.2	SCU	None

3.1.2.3.3 SOP SPECIFIC CONFORMANCE

DxMM uses only hierarchical queries.

DxMM may send a C-CANCEL request during a query operation.

The following table identifies the match support used by the DxMM AE.

Table 8: Matching Key Types

RV	Range Value match
SV	Single Value match
WC	Wild Card match
RET	Return value only

DxMM AE uses the following elements for Query/Retrieve service.

Table 9: Keys used in Patient Root Query/Retrieve

Level (0008,0052)	Description	Tag	Support
PATIENT	Patient's Name	(0010,0010)	WC
	Patient ID	(0010,0020)	WC
	Patient's Birth Date	(0010,0030)	RET
	Patient's Sex	(0010,0040)	RET
STUDY	Study Date	(0008,0020)	RV
	Study Time	(0008,0030)	RET
	Accession Number	(0008,0050)	WC
	Study ID	(0020,0010)	WC
	Study Instance UID	(0020,000D)	SV
	Modalities in Study	(0008,0061)	SV

	Referring Physician	(0008,0090)	RET
	Study Description	(0008,1030)	RET
SERIES	Modality	(0008,0060)	SV
	Series Description	(0008,103E)	RET
	Body Part Examined	(0018,0015)	RET
	Series Number	(0020,0011)	SV
	Series Instance UID	(0020,000E)	SV
COMPOSITE OBJECT INSTANCE	Instance Number	(0020,0060)	SV
	SOP Instance UID	(0008,0018)	SV
IMAGE SPECIFIC	Rows	(0028,0010)	RET
	Columns	(0028,0011)	RET
	Bits Allocated	(0028,0100)	RET
	Number of Frames	(0028,0008)	RET

Table 10: Keys used in Study Root Query/Retrieve

Level (0008,0052)	Description	Tag	Support
STUDY	Patient's Name	(0010,0010)	WC
	Patient ID	(0010,0020)	WC
	Patient's Birth Date	(0010,0030)	RET
	Patient's Sex	(0010,0040)	RET
	Study Date	(0008,0020)	RV
	Study Time	(0008,0030)	RET
	Accession Number	(0008,0050)	WC
	Study ID	(0020,0010)	WC
	Study Instance UID	(0020,000D)	SV
	Modalities in Study	(0008,0061)	SV
	Referring Physician	(0008,0090)	RET
	Study Description	(0008,1030)	RET
SERIES	Modality	(0008,0060)	SV
	Series Description	(0008,103E)	RET
	Body Part Examined	(0018,0015)	RET
	Series Number	(0020,0011)	SV
	Series Instance UID	(0020,000E)	SV
COMPOSITE OBJECT INSTANCE	Instance Number	(0020,0060)	SV
	SOP Instance UID	(0008,0018)	SV
IMAGE SPECIFIC	Rows	(0028,0010)	RET
	Columns	(0028,0011)	RET
	Bits Allocated	(0028,0100)	RET
	Number of Frames	(0028,0008)	RET

3.1.2.4 PRINT TO A REMOTE IMAGER

3.1.2.4.1 ASSOCIATED REAL-WORLD ACTIVITY

DxMM AE initiates associations to remote printers in order to print images on those printers.

3.1.2.4.2 PROPOSED PRESENTATION CONTEXTS

DxMM supports the Print (Meta) SOP Class fully as specified in the DICOM Standard.

The presentation contexts proposed by the DxMM AE for printing operations are specified in the following table:

Table 11: Printing Presentation Contexts of DxMM

Presentation Context Table					
Abstract Syntax		Transfer Syntax		Role	Extended Negotiation
Name	UID	Name	UID		
Basic Grayscale Print Management Meta	1.2.840.10008.5.1.1.9	Implicit VR, Little Endian	1.2.840.10008.1.2	SCU	None
Basic Color Print Management Meta	1.2.840.10008.5.1.1.18	Implicit VR, Little Endian	1.2.840.10008.1.2	SCU	None
Print Job SOP	1.2.840.10008.5.1.1.14	Implicit VR, Little Endian	1.2.840.10008.1.2	SCU	None
Printer Configuration Retrieval SOP Class	1.2.840.10008.5.1.1.16.376	Implicit VR, Little Endian	1.2.840.10008.1.2	SCU	None

3.1.2.4.3 SOP SPECIFIC CONFORMANCE FOR BASIC GRAYSCALE AND COLOR PRINT MANAGEMENT META SOP CLASSES

DxMM always uses STANDARD\1,1 image display format. DxMM makes arrangement of image boxes and annotation burning before sending film to the printer.

DxMM supports the following SOP classes as defined by the Basic Grayscale Print Management Meta class:

Table 12: Supported SOP classes as Basic Grayscale Print Management Meta SOP class

SOP Class Name	SOP Class UID
Basic Film Session	1.2.840.10008.5.1.1.1
Basic Film Box	1.2.840.10008.5.1.1.2
Basic Grayscale Image Box	1.2.840.10008.5.1.1.4
Printer	1.2.840.10008.5.1.1.16

DxMM supports the following SOP classes as defined by the Basic Color Print Management Meta class:

Table 13: Supported SOP classes as Basic Color Print Management Meta SOP class

SOP Class Name	SOP Class UID
Basic Film Session	1.2.840.10008.5.1.1.1
Basic Film Box	1.2.840.10008.5.1.1.2
Basic Color Image Box	1.2.840.10008.5.1.1.4.1
Printer	1.2.840.10008.5.1.1.16

Basic Film Session:

DxMM includes the following attributes in the N-CREATE for the Basic Film Session SOP class:

Table 14: Attribute for Basic Film Session SOP class N-CREATE

Description	Tag
Number of Copies	(2000,0010)
Print Priority	(2000,0020)
Medium Type	(2000,0030)
Film Destination	(2000,0040)
Film Session Label	(2000,0050)
Owner ID	(2100,0160)

The N-SET and N-ACTION are unused. The N-DELETE is used to delete the complete Basic Film Session SOP instance hierarchy.

Basic Film Box:

DxMM includes the following attributes in the N-CREATE for the Basic Film Box SOP class:

Table 15: Attribute for Basic Film Box SOP class N-CREATE

Description	Tag
Referenced Film Session Sequence	(2010,0500)
> Referenced SOP Class UID	(0008,1150)
> Referenced SOP Instance UID	(0008,1155)
Film Orientation	(2010,0040)
Film Size ID	(2010,0050)
Magnification Type	(2010,0060)
Smoothing Type	(2010,0080)
Border Density	(2010,0100)
Empty Image Density	(2010,0110)
Trim	(2010,0140)
Configuration Information	(2010,0150)
Requested Resolution ID	(2020,0050)

The N-SET is unused. The N-ACTION is used to print a complete Basic Film Box SOP instance and N-DELETE is used to delete it after printing.

Basic Grayscale Image Box:

DxMM includes the following attributes in the N-SET for the Basic Grayscale Image Box SOP class:

Table 16: Attribute for Basic Grayscale Image Box SOP class N-SET

Description	Tag
Polarity	(2020,0020)
Requested Image Size	(2020,0030)
Requested Decimate Crop Behavior	(2020,0040)
Preformatted Grayscale Image Sequence	(2020,0110)
> Samples Per Pixel	(0028,0002)
> Photometric Interpretation	(0028,0004)
> Rows	(0028,0010)
> Columns	(0028,0011)
> Pixel Aspect Ratio	(0028,0034)
> Bits Allocated	(0028,0100)
> Bits Stored	(0028,0101)
> High Bit	(0028,0102)
> Pixel Representation	(0028,0103)
> Pixel Data	(7FE0,0010)

DxMM only supports 8-bit printing.

Basic Color Image Box:

DxMM includes the following attributes in the N-SET for the Basic Grayscale Image Box SOP class:

Table 17: Attribute for Basic Grayscale Image Box SOP class N-SET

Description	Tag
Polarity	(2020,0020)
Requested Image Size	(2020,0030)
Requested Decimate Crop Behavior	(2020,0040)
Preformatted Color Image Sequence	(2020,0111)
> Samples Per Pixel	(0028,0002)
> Photometric Interpretation	(0028,0004)
> Planar Configuration	(0028,0006)
> Rows	(0028,0010)
> Columns	(0028,0011)
> Pixel Aspect Ratio	(0028,0034)
> Bits Allocated	(0028,0100)
> Bits Stored	(0028,0101)
> High Bit	(0028,0102)
> Pixel Representation	(0028,0103)
> Pixel Data	(7FE0,0010)

DxMM can optionally request this SOP Class from the SCP. In this case, DxMM will track the progress of current job using N-EVENT-REPORT and will not send another job before completion of the current.

3.1.3 ASSOCIATION ACCEPTANCE POLICY FOR DxMM AE

The DxMM Application Entity accepts associations for the Verification Service and Storage Services.

DxMM rejects association requests from application of which the AE Title is not registered within DxMM. The same applies to the case where the remote system uses a wrong AE Title to connect with DxMM.

An association is closed when there is no activity (i.e., no message received) for a configurable amount of time.

3.1.3.1 VERIFY COMMUNICATION WITH A REMOTE SYSTEM

The DxMM Application Entity waits for an association request and accepts associations to do, among other things, the Verification Service. The association is aborted if an error occurs and is closed when the initiator requests that it be closed.

3.1.3.1.1 *ASSOCIATED REAL-WORLD ACTIVITY*

DxMM performs an echo response after it receives a DICOM Echo request.

3.1.3.1.2 *ACCEPTED PRESENTATION CONTEXTS*

Only the presentation context listed in the following table will be accepted by DxMM for the Verification SOP Class.

Table 18: Echo Response Presentation Contexts of DxMM

Presentation Context Table					
Abstract Syntax		Transfer Syntax		Role	Extended Negotiation
Name	UID	Name	UID		
Verification SOP Class	1.2.840.10008.1.1	Implicit VR Little Endian	1.2.840.10008.1.2	SCP	None

3.1.3.1.3 *SOP SPECIFIC CONFORMANCE*

DxMM AE provides standard conformance to the DICOM Verification Service Class.

3.1.3.1.4 *PRESENTATION CONTEXT ACCEPTANCE CRITERION*

The shown presentation context above is always accepted.

3.1.3.2 RECEIVE OBJECTS FROM A REMOTE SYSTEM

The DxMM Application Entity waits for an association request and accepts associations to do, among other things, the Image Storage Service. The association is aborted if an error occurs and is closed when the initiator requests that it be closed.

3.1.3.2.1 *ASSOCIATED REAL-WORLD ACTIVITY*

Once the association has been established, the DxMM AE waits for transmission of conformant Storage Service messages. Images received are decoded, following the configuration, images are stored in a DICOMDIR, or are saved in a simple folder or in the DxMM DICOM cache.

3.1.3.2.2 ACCEPTED PRESENTATION CONTEXTS

The presentation contexts that will be accepted by the DxMM AE for the Receive Object operation are listed in following table:

Table 19: Receive Object Presentation Contexts of DxMM

Presentation Context Table					
Abstract Syntax		Transfer Syntax		Role	Extended Negotiation
Name	UID	Name	UID		
See Note	See Note	Implicit VR Little Endian	1.2.840.10008.1.2	SCP	None
		Explicit VR Little Endian	1.2.840.10008.1.2.1		
		Explicit VR Big Endian	1.2.840.10008.1.2.2		
		Explicit VR Little Endian, JPEG baseline encoded	1.2.840.10008.1.2.4.50		
		Explicit VR Little Endian, JPEG baseline encoded	1.2.840.10008.1.2.4.51		
		Explicit VR Little Endian, JPEG loss less encoded	1.2.840.10008.1.2.4.70		
		Explicit VR Little Endian, RLE loss less	1.2.840.10008.1.2.5		

Note: Include all abstract syntaxes from table 2

3.1.3.2.3 SOP SPECIFIC CONFORMANCE

The DxMM AE conforms to the SOP's of the Storage SOP Class at Level 2 (Full). No elements are discarded or coerced by DxMM AE. In addition private attributes will be stored and included when the object is sent out again.

The DxMM AE responds to a C-STORE request with one of these response codes:

Table 20: C-STORE Response Codes

Service Status	Status Description	Status Code (0000,0900)	Related Fields
Refused	Out of Resources – There were insufficient resources to process the request. The request was not processed.	A765	(0000,0902) contains a short description of the condition.
Success		0000	None

3.1.3.2.4 PRESENTATION CONTEXT ACCEPTANCE CRITERION

The shown presentation context above is always accepted.

3.1.3.2.5 TRANSFER SYNTAX SELECTION POLICIES

The DxMM AE selects the first proposed transfer syntax as soon as it is compatible with table 7.

3.2 DxMM MEDIA STORAGE AE

DxMM provides standard conformance to the DICOM Media Storage Service and File Format and the Media Storage Application Profiles.

DxMM supports the following application profile:

Table 21: DxMM Media Storage Application Profile

Description	Identifier
General Purpose CD-R Image Interchange profile	STD-GEN-CD

DxMM supports the following Real World Activities within the profile mentioned above:

Table 22: DxMM Media Storage Real World Activities

Real-World Activity	Role	SC Option
Display Directory of CD-R disk	FSR	Interchange
Read image(s) from CD-R disk	FSR	Interchange
Write image(s) on CD-R disk	FSC,FSU	Interchange

DxMM does not write CD-R's itself, but it is able to prepare the contents in a way that third party software could create DICOM Part 10 compliant CD-R volume.

3.2.1 REAL-WORLD ACTIVITY: DISPLAY DIRECTORY OF CD-R DISK

DxMM will act as a FSR when reading the directory of the medium. This will result in a list of the patients, studies, series and images in the DxMM selection window. Information is displayed in the same way as information coming from DxServer or a DICOM server.

Table 23: DICOMDIR keys displayed in DxMM

Level	Displayed fields	Tag
Patient	Patient's Name	(0010,0010)
	Patient ID	(0010,0020)
	Patient's Birth Date	(0010,0030)
	Patient's Sex	(0010,0040)
Study	Study Date	(0008,0020)
	Study Time	(0008,0030)
	Accession Number	(0008,0050)
	Study ID	(0020,0010)
	Study Instance UID	(0020,000D)
	Study Description	(0008,1030)
Series	Modality	(0008,0060)
	Series Description	(0008,103E)
	Performing Physician's Name	(0008,1050)
	Series Instance UID	(0020,000E)
	Series Number	(0020,0011)
Image	Image Number	(0020,0013)
	Number of Frames	(0028,0008)
	Rows	(0028,0010)
	Columns	(0028,0011)

3.2.2 REAL-WORLD ACTIVITY: READ IMAGES FROM CD-R DISK

DxMM will act as a FSR when reading images from the CD-R medium.

DxMM is able to read images that belong to one of the SOP classes listed in Table 2.

DxMM is able to read images that have one of the following transfer syntaxes:

Table 24: Transfer Syntaxes for DICOM part 10 images

Name	UID
Implicit VR Little Endian	1.2.840.10008.1.2
Explicit VR Little Endian	1.2.840.10008.1.2.1
Explicit VR Big Endian	1.2.840.10008.1.2.2
Explicit VR Little Endian, JPEG baseline encoded	1.2.840.10008.1.2.4.50
Explicit VR Little Endian, JPEG baseline encoded	1.2.840.10008.1.2.4.51
Explicit VR Little Endian, JPEG loss less encoded	1.2.840.10008.1.2.4.70
Explicit VR Little Endian, RLE loss less	1.2.840.10008.1.2.5

3.2.3 REAL-WORLD ACTIVITY: WRITE IMAGES

DxMM will act as a FSC or FSU when writing patients, studies, series or images from one source (DxServer, DICOM server, DICOMDIR) to random access archive media.

The Implementation Class UID is 1.2.250.1.38.1.3.3.1.1.

DxMM is able to write images that belong to one of the SOP classes listed in Table 2.

DxMM is able to write images in one of the following transfer syntaxes:

Table 25: Transfer Syntaxes for DICOM part 10 images

Name	UID
Implicit VR Little Endian	1.2.840.10008.1.2
Explicit VR Little Endian	1.2.840.10008.1.2.1
Explicit VR Big Endian	1.2.840.10008.1.2.2
Explicit VR Little Endian, JPEG baseline encoded	1.2.840.10008.1.2.4.50
Explicit VR Little Endian, JPEG baseline encoded	1.2.840.10008.1.2.4.51
Explicit VR Little Endian, JPEG loss less encoded	1.2.840.10008.1.2.4.70
Explicit VR Little Endian, RLE loss less	1.2.840.10008.1.2.5

DxMM keeps the original transfer syntax when writing images.

DxMM creates DICOMDIR files containing the following keys:

Table 26: DICOMDIR keys

Directory Record Type	Displayed fields	Tag
PATIENT	Patient's Name	(0010,0010)
	Patient ID	(0010,0020)
	Patient's Birth Date	(0010,0030)
	Patient's Sex	(0010,0040)
STUDY	Study Date	(0008,0020)
	Study Time	(0008,0030)
	Accession Number	(0008,0050)
	Study ID	(0020,0010)
	Study Instance UID	(0020,000D)
	Study Description	(0008,1030)
SERIES	Modality	(0008,0060)
	Series Description	(0008,103E)
	Performing Physician's Name	(0008,1050)
	Series Instance UID	(0020,000E)
	Series Number	(0020,0011)
IMAGE	Image Number	(0020,0013)
	Number of Frames	(0028,0008)
	Rows	(0028,0010)
	Columns	(0028,0011)
	Referenced SOP Class UID In File	(0004,1510)
	Referenced SOP Instance UID In File	(0004,1511)
	Referenced Transfer Syntax UID In File	(0004,1512)
	Referenced File ID	(0004,1500)

4 COMMUNICATION PROFILES

4.1 SUPPORTED COMMUNICATIONS STACKS

DxMM provides DICOM V3.0 TCP/IP Network Communication Support as defined in PS 3.8.

4.2 TCP/IP STACK

DxMM inherits the TCP/IP stack from the MS Windows system upon which it executes.

4.3 PHYSICAL MEDIA SUPPORT

DxMM is indifferent to the physical medium over which TCP/IP executes; they inherit this from the MS Windows system upon which they execute.

5 EXTENSIONS / SPECIALIZATIONS / PRIVATIZATIONS

No extended, specialized or private SOP classes are supported.

No private transfer syntaxes are supported.

6 CONFIGURATION

See [1] for full details.

7 SUPPORT OF EXTENDED CHARACTER SETS

DxMM supports the following character sets:

Table 27: Character sets

Code Element	Description
ISO-IR 6	Default character set
ISO-IR 100	Latin alphabet n°1
ISO-IR 13	Japanese katakana (phonetic) characters (94 characters)
ISO-IR 87	Japanese kanji (ideographic), hiragana (phonetic), and katakana (phonetic) characters (94 ² characters, 2-byte)

8 SECURITY

8.1 SECURITY PROFILES

Dx MM supports secure DICOM communication in conformance with the Basic TLS Secure Transport Connection Profile. This support is an option of the installation setup and can be disabled.

8.2 ASSOCIATION LEVEL SECURITY

By default, Dx MM accepts association requests from only registered calling AE Titles. This behavior can be disabled in configuration file by an administrator.

8.3 APPLICATION LEVEL SECURITY

Dx MM can be configured to require user authentication in order to access to the user interface functionalities. This configuration is done in Dx Server user interface